

Yamato

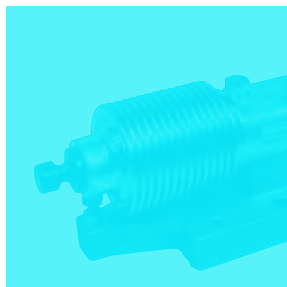

Load Cell

ロードセル

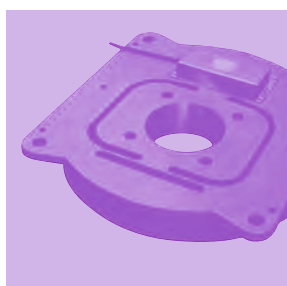

ロードセルの取付方法

How to Install your Load Cell

ロードセルの取付方法を大別すると、下記のようになります。

A broad categorization of installation methods for load cells appears below.

簡易法

1個または2個のロードセルを用いる方法で、電気的な構成が簡単で費用も幾分安くなりますが、一部をロードセルの代りにヒンジ類で支える必要があり、レベル計測等、測定精度をあまり必要としない場合に用いられます。

For methods involving the use of one or two load cells, electrical configurations are simple and somewhat cost efficient. However, it will be necessary to support part of the units by mountings, which substitute for the load cells. These can be used if level measurements or measurement precision aren't deemed entirely necessary.

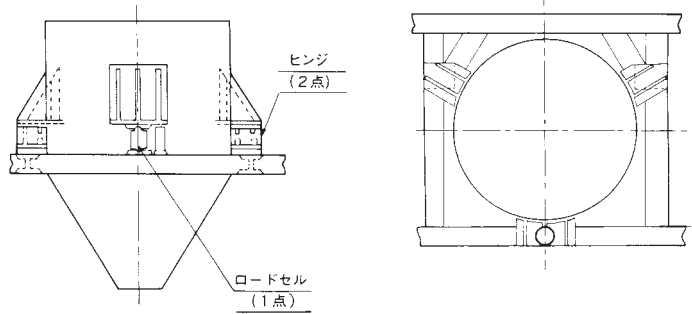

マルチ・ロードセル法

複数個(3個以上)のロードセルを用いる方法で、最も標準的な取付方法といえます。ロードセルの数量は、一般的には3~4個ですが、重量物を測定する場合等、必要に応じて、6~8個用いられます。最大使用個数は、計器の仕様等により異なります。

Multi-load cell method

This is said to be the most standard method when several units (at least three) are installed.

The number of units is generally three or four. If heavy items are to be measured, six to eight units may be used depending on the requirements. The maximum number of units varies depending on the specification of the gauges.

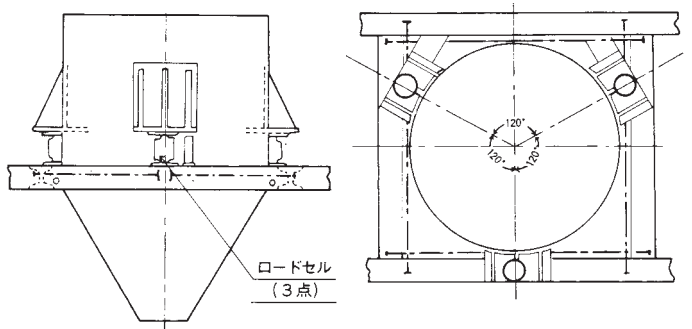

槓桿併用法

右図の様に、槓桿とロードセル1個を組合せた方法を槓桿併用法といいます。

ホッパーの自重は、バランス用のおもりで打消すことができますので、適当な槓桿比を選べばロードセルは小容量となり、定格容量に近いところまで活用することができます。

Lever combination method

As shown in the illustration on the right, using a lever in combination with a load cell is called the lever combination method.

As the weight of a hopper can be offset with balance weights, the load cell becomes low capacity and can be used almost to the point of its standard capacity if the appropriate linkage ratio is selected.

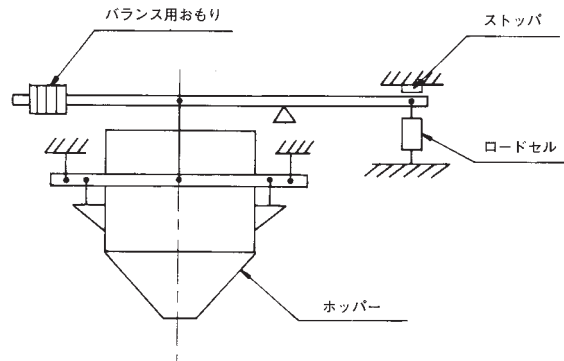

ロードセルの取付方法〈例:ホッパー・タンク秤〉 Load cell installation method (For hoppers and tank scales)

種類	圧縮方式			吊下げ方式				
形状								
ロードセル個数	4	3	4	3	1	4	2	
チェックロッドの数	3~8	3~8	3~8	0~8	0~8	0~8	0~8	
ヒンジまたはダミを用いる簡易法(液体のみ)	否	可 ロードセル数を2または1とする	否	可 ロードセル数を2または1とする	/		否	可 ロードセル数を1とする

ロードセル取付金具 MOUNTING BRACKETS FOR LOAD CELLS

ロードセルをタンクやホッパーの「荷重検出器」として使用するためには、ロードセル本体のほかに、それぞれのロードセルに適した取付金具が必要になります。

Mounting brackets must correspond with the load cell's body as well as the different types of load cells so that they can be used as "load sensing instruments" for tanks or hoppers.

圧縮形の場合 For compression types

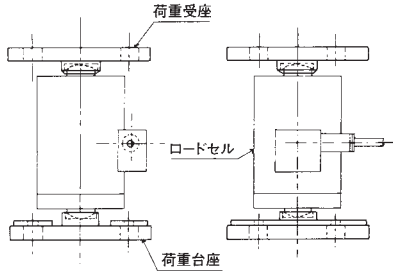

例：CC2型

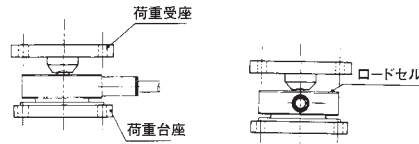

例：CD2型

引張形の場合 For tension types

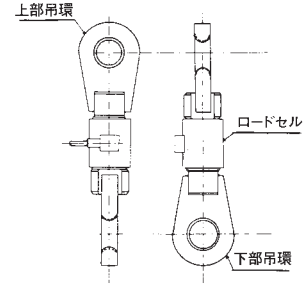

例：TC1型

(注記) 圧縮形のロードセル (CC2, CC5) の場合、両頭式を採用し、復元力が大きくなっているため、持別の自在金具を必要とせず、取付が簡単になっているのが特長です。

Note: The double-headed approach is employed for compression-type load cells (CC2, CC5). A feature of this is that the installation is made easy, without the need for adjustable brackets, in order to enhance the stabilizing force.

チェックロッド CHECK ROD

ホッパー・タンク等には、風圧、接続パイプの圧力によるブルドン現象、熱膨張等により、横荷重が発生します。この横荷重による移動または転倒を防止するため、チェックロッドが必要になります。

Lateral load occurs in tanks and hoppers, etc., due to the Bourdon phenomenon caused by wind pressure or pressure from connecting pipes, and to thermal expansion and other factors. A check rod will be necessary to stem movement or collapse caused by this lateral load.

棒状チェックロッド (引張・圧縮両用)

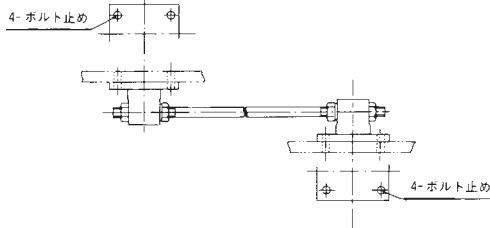

ターンバックル状チェックロッド (引張専用)

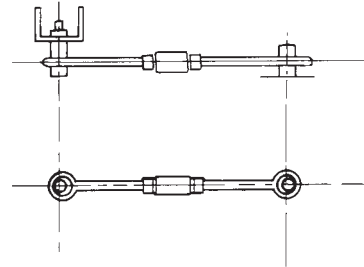

チェックロッド使用例 AN EXAMPLE OF CHECK ROD USE

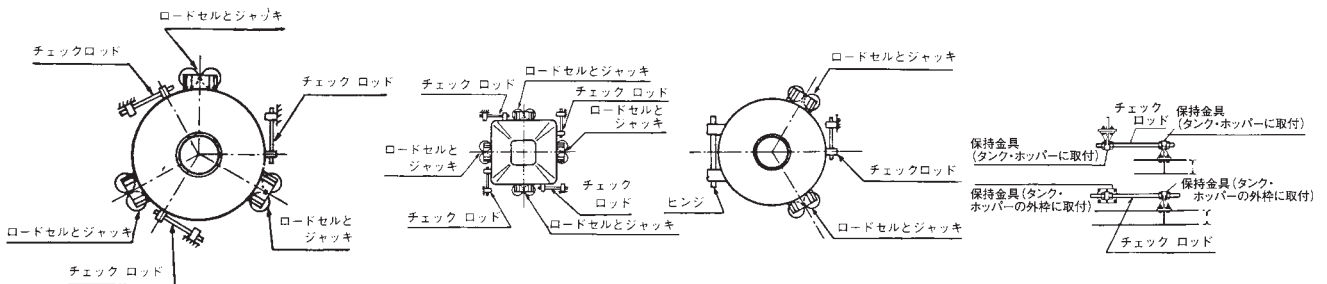

最もおすすめできる無理のない取り付け

角形ホッパー等の場合

2点検出、1点ヒンジの場合

チェックロッド取り付けの例

CC2

**Capacity; 10, 20, 30, 50, 70,
100t**

**Double Convex Loading
Easily Installation
Hermetically Sealed**

数々の改良技術とリニアライゼーションテクニックを採用し、飛躍的に性能をグレードアップした代表的な大容量圧縮ロードセルであり、その優れた直線性、クリープ特性、温度特性が認められて電子式トラックスケール、台はかり等の大形はかりの精密計量の荷重検出器として広く利用されています。

This is a high-capacity compression load cell that represents a significant step up in performance as it employs a number of improved technologies. Its outstanding linearity, creep feature and temperature features have been proven, as it is widely used as a load sensing instrument for precise measurements of large-scale weighing such as electronic track scales and platform weighing.



SPECIFICATIONS			Accuracy Class	
			U 級	V 級
PERFORMANCE				
定格荷重出力	Reted Output (R.O.)	mv/v	1.5±0.002	1.5±0.002
直線性(ヒステリシスを含む)	Linearity including hysteresis	% of R.O.	±0.02	±0.03
繰返し性	Repeatability	% of R.O.	±0.01	±0.015
クリープ(30分値)	Creep	% of R.O.	±0.02	±0.03
クリープ回復性	Recovery	% of R.O.	±0.02	±0.03
ELECTRICAL				
推奨印加電圧	Recommended excitation voltage	V ac or dc	10	10
最大印加電圧	Maximum excitation voltage	V ac or dc	15	15
零バランス	Zero balance	% of R.O.	±1	±1
入力端子間抵抗	Input terminal resistance	Ohms	350±5	350±5
出力端子間抵抗	Output terminal resistance	Ohms	351±1	351±1
ケーブル長さ	Cable length	m	5	5
絶縁抵抗	Insulation resistance	Ohms	5000M	5000M
TEMPERATURE				
補償温度範囲	Compensated temperature range	℃	-10~+60	-10~+60
許容温度範囲	Safe temperature range	℃	-30~+80	-30~+80
出力の温度特性	Temperature effect on load	% of Reading/10℃	±0.01	±0.015
零点の温度特性	Temperature effect on zero balance	% of R.O./5℃	±0.01	±0.015
ADVERSE LOAD RATING				
許容過負荷	Safe overload	% of Rated Capacity	150	150
限界過負荷	Ultimate overload	% of Rated Capacity	300	300

(注) 避雷保護付の場合、外部からの測定した絶縁抵抗は100MΩ以上とします。

外形寸法図 DIMENSIONS

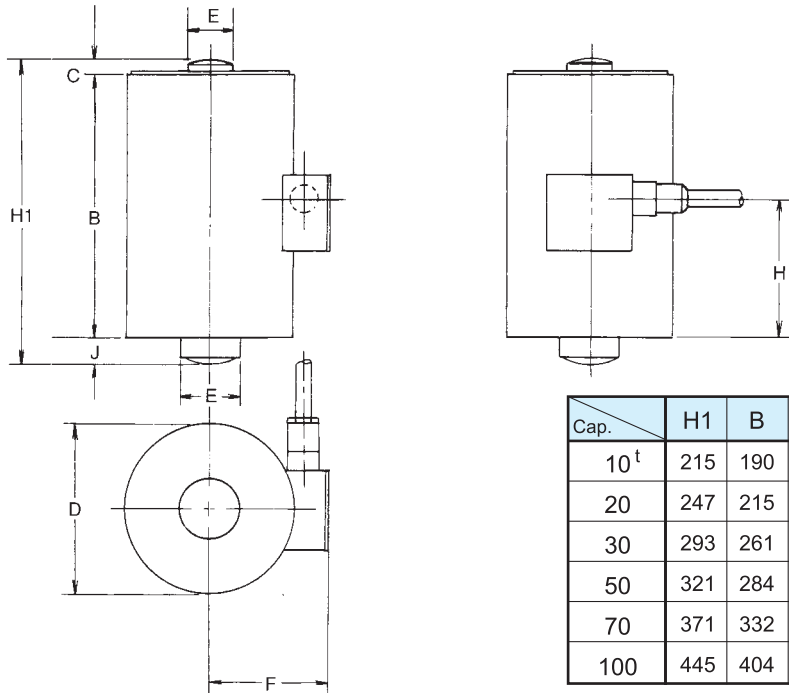

單位：mm

Cap.	H1	B	C	φD	φE	F	H	J	WT. (kg)
10 ^t	215	190	11	125	28/40	89.5	98	14	13
20	247	215	12	135	33/47	94.5	118	20	16
30	293	261	12	160	40/55	108.0	136	20	26
50	321	284	17	175	55/66	116.8	150	20	38
70	371	332	17	200	62/79	149.2	175	22	50
100	445	404	18	242	79/94	152.3	214	23	115

装着説明図 MOUNTING ACCESSORY

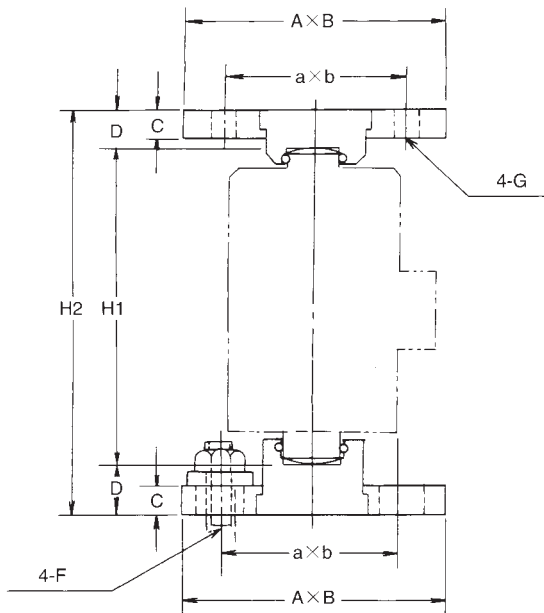

■ 結線図

ELECTRICAL TERMINATION

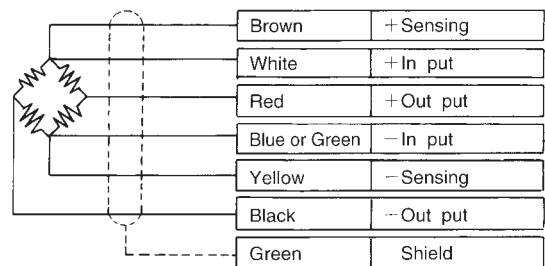

單位：mm

Cap.	A	a	B	b	C	D	F	G	H1	H2
10 ^t	200	140	170	110	19	30	M20	φ22	215	274
20	200	140	170	110	22	42	M20	φ22	247	330
30	240	180	200	140	25	54	M24	φ26	293	400
50	255	195	215	155	25	62	M24	φ26	321	445
70	280	220	235	175	32	73	M24	φ26	371	517
100	310	250	250	190	33	88	M24	φ26	445	621

CC21

Capacity; 12, 24, 36t

Double Convex Loading
Easily Installation
Hermetically Sealed

従来のCC2型ロードセルと同等の優れた直線性、クリープ特性、温度特性が認められ、電子式トラックスケールを主体に大形はかりの精密計量の荷重検出器として広く利用されています。

Its outstanding linearity, creep and temperature characteristics, which are in line with the previous CC2 model, have been proven. It's widely used as a load-sensing instrument mainly for precise measurements in large-scale weighing such as electronic track scales.



SPECIFICATIONS			Accuracy Class	
			U 級	V 級
PERFORMANCE				
定格荷重出力	Reted Output (R.O.)	mv/v	1.8±0.002	1.8±0.002
直線性(ヒステリシスを含む)	Linearity including hysteresis	% of R.O.	±0.02	±0.03
繰返し性	Repeatability	% of R.O.	±0.01	±0.015
クリープ(30分値)	Creep	% of R.O.	±0.02	±0.03
クリープ回復性	Recovery	% of R.O.	±0.02	±0.03
ELECTRICAL				
推奨印加電圧	Recommended excitation voltage	V ac or dc	10	10
最大印加電圧	Maximum excitation voltage	V ac or dc	15	15
零バランス	Zero balance	% of R.O.	±1	±1
入力端子間抵抗	Input terminal resistance	Ohms	350±5	350±5
出力端子間抵抗	Output terminal resistance	Ohms	351±1	351±1
ケーブル長さ	Cable length	m	5	5
絶縁抵抗	Insulation resistance	Ohms	5000M	5000M
TEMPERATURE				
補償温度範囲	Compensated temperature range	℃	-10~+60	-10~+60
許容温度範囲	Safe temperature range	℃	-30~+80	-30~+80
出力の温度特性	Temperature effect on load	% of Reading/10℃	±0.01	±0.015
零点の温度特性	Temperature effect on zero balance	% of R.O./5℃	±0.01	±0.015
ADVERSE LOAD RATING				
許容過負荷	Safe overload	% of Rated Capacity	150	150
限界過負荷	Ultimate overload	% of Rated Capacity	300	300

(注) 避雷保護付の場合、外部からの測定した絶縁抵抗は100MΩ以上とします。

外形寸法図 DIMENSIONS

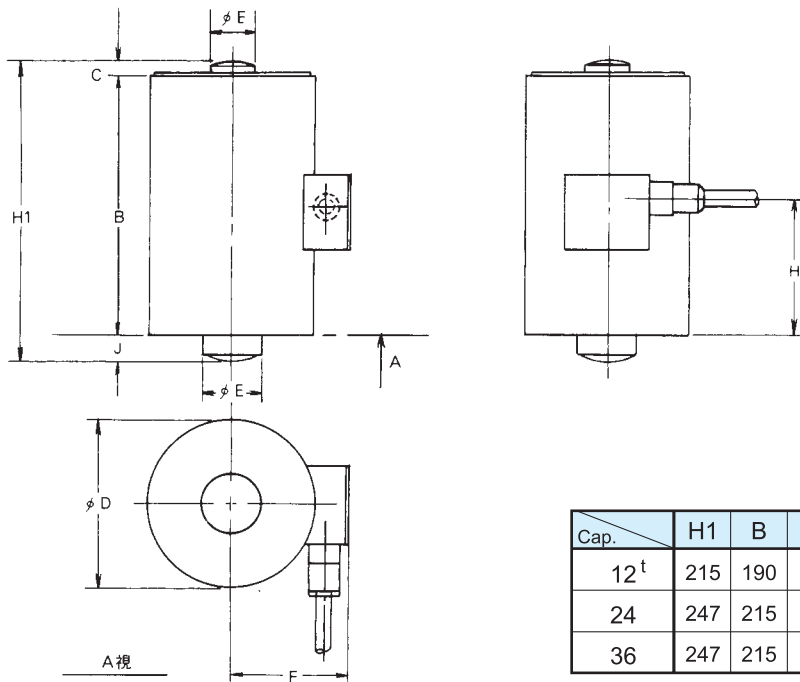

単位: mm

Cap.	H1	B	C	φD	φE	F	H	J	WT. (kg)
12 ^t	215	190	11	135	28/40	94.5	104.5	14	15
24	247	215	12	135	33/47	94.5	104.5	20	17
36	247	215	12	135	40/47	94.5	104.5	20	18

装着説明図 MOUNTING ACCESSORY

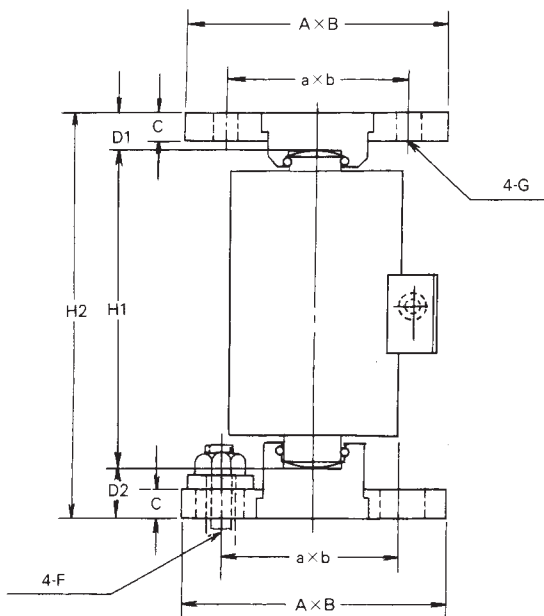

結線図

ELECTRICAL TERMINATION

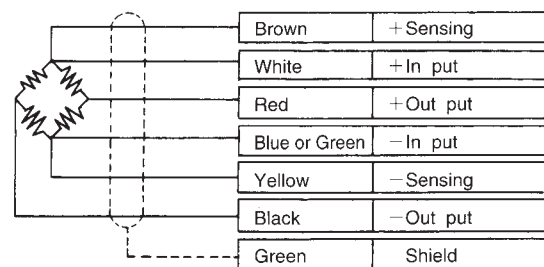

単位: mm

Cap.	A	a	B	b	C	D1	D2	F	G	H1	H2
12 ^t	200	140	170	110	19	29.5	29.5	M20	φ22	215	274
24	200	140	170	110	22	41.5	41.5	M20	φ22	247	330
36	240	180	200	140	25	53.5	41.5	M24	φ26	247	342

CC5

**Capacity; 10, 20, 30, 50, 70,
100, 150, 200, 300,
500t**

**Double Convex Loading
Low Deflection
Hermetically Sealed**

比較的小さい形状で耐荷重を大きくしたこの低コスト大容量圧縮ロードセルは、ダブルコンベックス・ローディング方式を採用しているため、特別の自在金具を使用しなくても抜群の復元性を有するところから、高精度の大容量ホッパー、タンク等の重量計測に広く利用され、その簡便な適用性、経済性を高く評価されております。

This low-cost, high-capacity compressor load cell has a relatively compact size and increases load bearing. As it employs double-convex loading, it's widely used for weighing for high-precision, large capacity hoppers, tankers and so on, due to its outstanding stabilizing ability. Its ease of application and economy have earned it much acclaim.



SPECIFICATIONS			Accuracy Class
			O(H) 級
PERFORMANCE			
定格荷重出力	Reted Output (R.O.)	mv/v	2.0±0.01
直線性(ヒステリシスを含む)	Linearity including hysteresis	% of R.O.	±0.05(±0.1)
繰返し性	Repeatability	% of R.O.	±0.02(±0.05)
クリープ(30分値)	Creep	% of R.O.	±0.06
クリープ回復性	Recovery	% of R.O.	±0.06
ELECTRICAL			
推奨印加電圧	Recommended excitation voltage	V ac or dc	10
最大印加電圧	Maximum excitation voltage	V ac or dc	15
零バランス	Zero balance	% of R.O.	±1
入力端子間抵抗	Input terminal resistance	Ohms	350±5
出力端子間抵抗	Output terminal resistance	Ohms	351±3
ケーブル長さ	Cable length	m	5
絶縁抵抗	Insulation resistance	Ohms	5000M
TEMPERATURE			
補償温度範囲	Compensated temperature range	℃	-10~+60
許容温度範囲	Safe temperature range	℃	-30~+80
出力の温度特性	Temperature effect on load	% of Reading/10℃	±0.06
零点の温度特性	Temperature effect on zero balance	% of R.O./5℃	±0.05
ADVERSE LOAD RATING			
許容過負荷	Safe overload	% of Rated Capacity	150
限界過負荷	Ultimate overload	% of Rated Capacity	300

(注) ・避雷保護付の場合、外部からの測定した絶縁抵抗は100MΩ以上とします。
・150t以上の精度級は(H)級となり特性は()内数値となります。

外形寸法図 DIMENSIONS

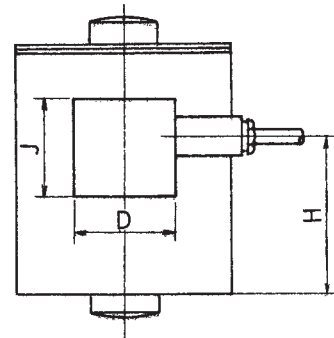
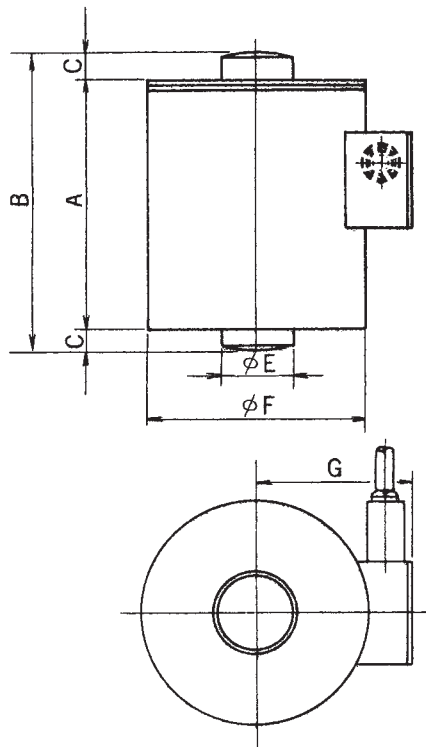

単位: mm

Cap.	A	B	C	D	φE	φF	G	H	J	WT. (kg)
10 ^t	88	110	11	60	21	80	62.5	51	53	3
20	93	115	11	60	30	90	69.5	54	53	4
30	101	125	12	60	38	100	76	63	53	5
50	125	155	15	67	49	125	88.8	86.5	60	10
70	146	182	18	67	59	145	100.3	98.5	60	16
100	160	200	20	67	70	175	116.8	101.5	60	25
150	198	248	25	67	84	210	135.5	126.5	60	45
200	225	275	25	67	99	230	146.5	152.5	60	62
300	282	340	29	67	119	270	167.3	188.5	60	105
500	350	410	30	67	154	335	200.6	226.5	60	210

装着説明図 MOUNTING ACCESSORY

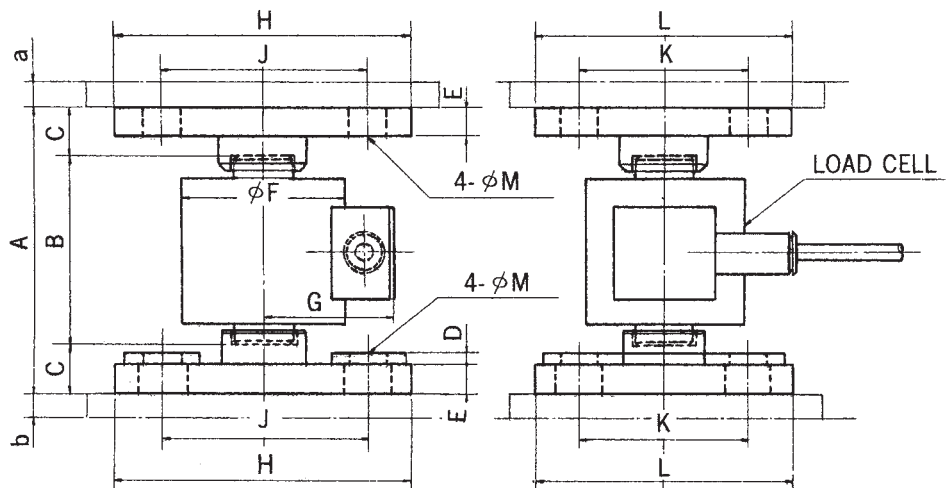

単位: mm

Cap.	A	B	C	D	E	φF	G	H	J	K	L	φM	WT. (kg)
10 ^t	170	110	30	9	16	80	62.5	140	100	80	130	18	10
20	175	115	30	9	19	90	69.5	140	100	80	130	18	11
30	205	125	40	12	22	100	76	190	130	110	170	22	18
50	255	155	50	12	25	125	88.8	200	140	120	180	22	26
70	300	182	59	12	25	145	100.3	210	150	120	190	26	35
100	340	200	70	12	32	175	116.8	240	180	160	230	26	55
150	430	248	91	12	40	210	135.5	290	220	220	290	33	105
200	494	275	109.5	16	45	230	146.5	340	250	250	340	39	150
300	600	340	130	16	55	270	167.3	410	300	300	410	45	260
500	760	410	175	16	70	350	200.6	480	360	360	480	51	480

■結線図

ELECTRICAL TERMINATION

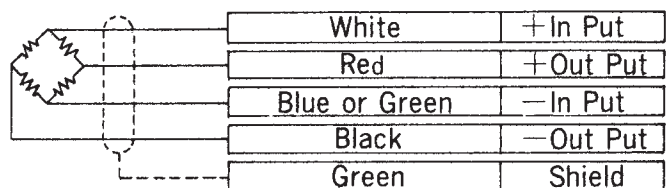

CC52

Capacity; 10, 20, 30, 50, 70t

Double Convex Loading
Low Deflection
Hermetically Sealed

比較的小さい形状で耐荷重を大きくしたこのロストワックス形圧縮ロードセルは、ダブルコンベックス・ローディング方式を採用しているため、特別の自在金具を使用しなくても抜群の復元性を有するところから、高精度の大容量ホッパー、タンク等の重量計測に広く利用され、その簡便な適用性、経済性を高く評価されております。

This lost-wax casting compressor load cell has a relatively compact size and increases load bearing. As it employs a double convex loading, it's widely used for weighing for high-precision, large capacity hoppers, tankers and so on, due to its outstanding stabilizing ability that doesn't use any special adjustable brackets. Its ease of application and economy have earned it high acclaim.



SPECIFICATIONS			Accuracy Class
			O 級
PERFORMANCE			
定格荷重出力	Reted Output (R.O.)	mv/v	2.0±0.01
直線性(ヒステリシスを含む)	Linearity including hysteresis	% of R.O.	±0.05
繰返し性	Repeatability	% of R.O.	±0.02
クリープ(30分値)	Creep	% of R.O.	±0.06
クリープ回復性	Recovery	% of R.O.	±0.06
ELECTRICAL			
推奨印加電圧	Recommended excitation voltage	V ac or dc	10
最大印加電圧	Maximum excitation voltage	V ac or dc	15
零バランス	Zero balance	% of R.O.	±1
入力端子間抵抗	Input terminal resistance	Ohms	350±5
出力端子間抵抗	Output terminal resistance	Ohms	351±3
ケーブル長さ	Cable length	m	5
絶縁抵抗	Insulation resistance	Ohms	5000M
TEMPERATURE			
補償温度範囲	Compensated temperature range	℃	-10~+60
許容温度範囲	Safe temperature range	℃	-30~+80
出力の温度特性	Temperature effect on load	% of Reading/10℃	±0.06
零点の温度特性	Temperature effect on zero balance	% of R.O./5℃	±0.05
ADVERSE LOAD RATING			
許容過負荷	Safe overload	% of Rated Capacity	150
限界過負荷	Ultimate overload	% of Rated Capacity	300

(注) 避雷保護付の場合、外部からの測定した絶縁抵抗は100MΩ以上とします。

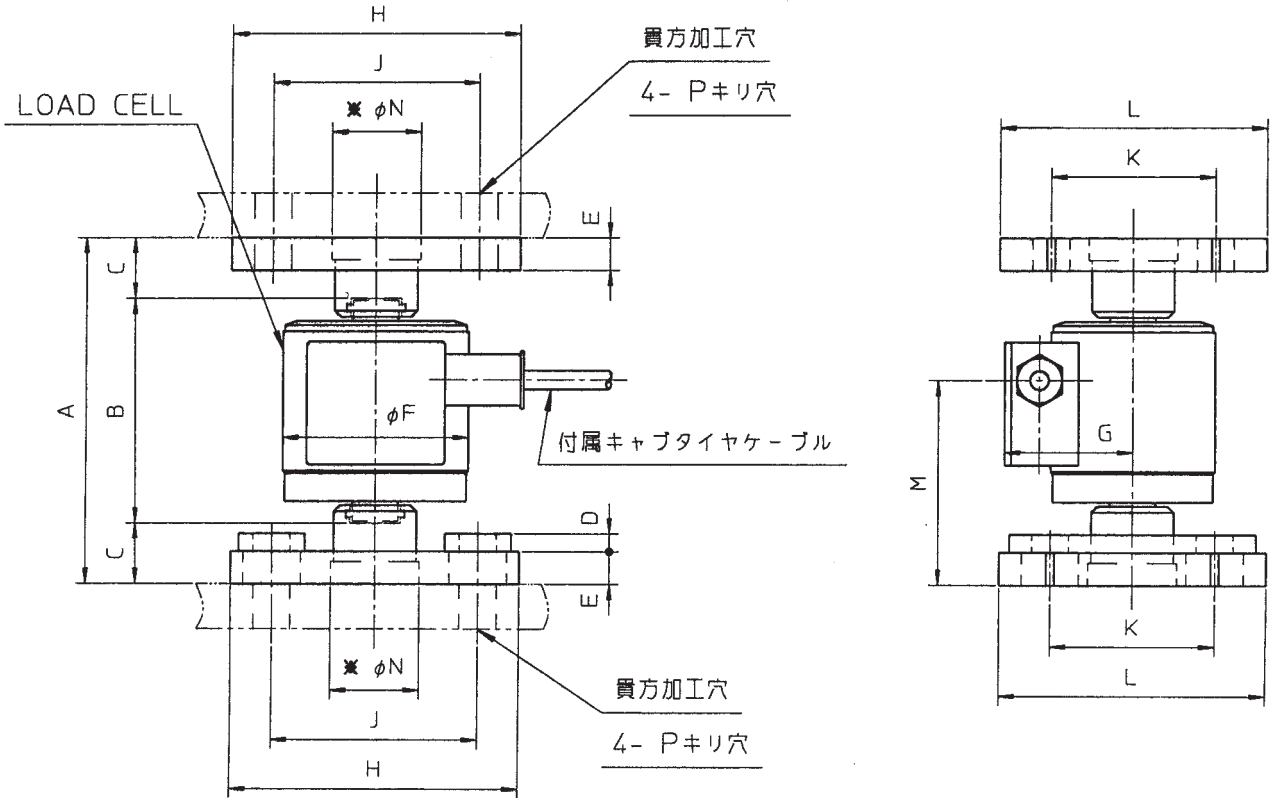

単位：mm

Cap.	A	B	C	D	E	ϕF	G	H	J	K	L	M	ϕN	P	WT. (kg)
10 ^t	170	110	30	9	16	90	62.5	140	100	80	130	100.5	43	18	約10
20	175	115	30	9	19	90	62.5	140	100	80	130	102.5	58	18	約10
30	205	125	40	12	22	125	84.5	190	130	110	170	124.5	74	22	約20
50	255	155	50	12	25	125	84.5	200	140	120	180	137.5	80	22	約25
70	300	182	59	12	25	125	84.5	210	150	120	190	149.5	92	26	約28

CC55

防爆構造および発火度;SDP13
型式の名称;CC55(屋外用)

Explosion-proof and ignition; SDP13
model name: CC55 (for outdoor use)

Capacity; 20, 30, 50, 70, 100,
150, 200, 300t

あらゆる粉じんの危険場所に使用するために開発されたロードセルで、完全金属シールに不活性ガス封入で大容量の高精度計測を可能にしたものです。

比較的小さい形状で耐荷重を大きくした大容量圧縮形ロードセルでダブルコンベックス・ローディング方式を採用しているため、特別の自在金具を使用しなくても抜群の復元性を有するところから高精度ホッパー、タンク、またレベル計等の重量計測に広く利用され、その簡便な適用性を高く評価されております。

This load cell was developed to be used in all sorts of places where dust can be a danger. It enables highly precise large-capacity measurements with inert gases sealed completely in metal. This low-cost, high capacity compressor load cell has a relatively compact size and increased load bearing. As it employs a double convex loading, it's widely used for weighing for high-precision, large capacity hoppers, tankers and so on, due to its outstanding stabilizing ability that doesn't use any special adjustable brackets. Its ease of application and economy have earned it high acclaim.

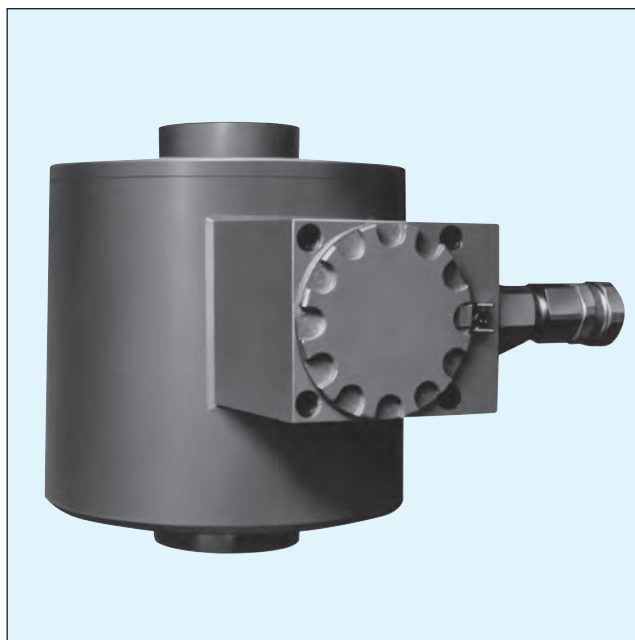

SPECIFICATIONS			Accuracy Class
			O(H)級
PERFORMANCE			
定格荷重出力	Reted Output (R.O.)	mv/v	2.0±0.01
直線性(ヒステリシスを含む)	Linearity including hysteresis	% of R.O.	±0.05(±0.1)
繰返し性	Repeatability	% of R.O.	±0.02(±0.05)
クリープ(30分値)	Creep	% of R.O.	±0.06
クリープ回復性	Recovery	% of R.O.	±0.06
ELECTRICAL			
推奨印加電圧	Recommended excitation voltage	V ac or dc	10
最大印加電圧	Maximum excitation voltage	V ac or dc	15
零バランス	Zero balance	% of R.O.	±1
入力端子間抵抗	Input terminal resistance	Ohms	350±5
出力端子間抵抗	Output terminal resistance	Ohms	351±3
ケーブル長さ	Cable length	m	5
絶縁抵抗	Insulation resistance	Ohms	5000M
TEMPERATURE			
補償温度範囲	Compensated temperature range	℃	-10~+60
許容温度範囲	Safe temperature range	℃	-30~+80
出力の温度特性	Temperature effect on load	% of Reading/10℃	±0.06
零点の温度特性	Temperature effect on zero balance	% of R.O./5℃	±0.05
ADVERSE LOAD RATING			
許容過負荷	Safe overload	% of Rated Capacity	150
限界過負荷	Ultimate overload	% of Rated Capacity	300

(注) ・避雷保護付の場合、外部からの測定した絶縁抵抗は100MΩ以上とします。
・150t以上の精度級は(H)級となり、特性は()内数値となります。

外形寸法図 DIMENSIONS

定格 20, 30t (型式検定合格番号 第32093号)

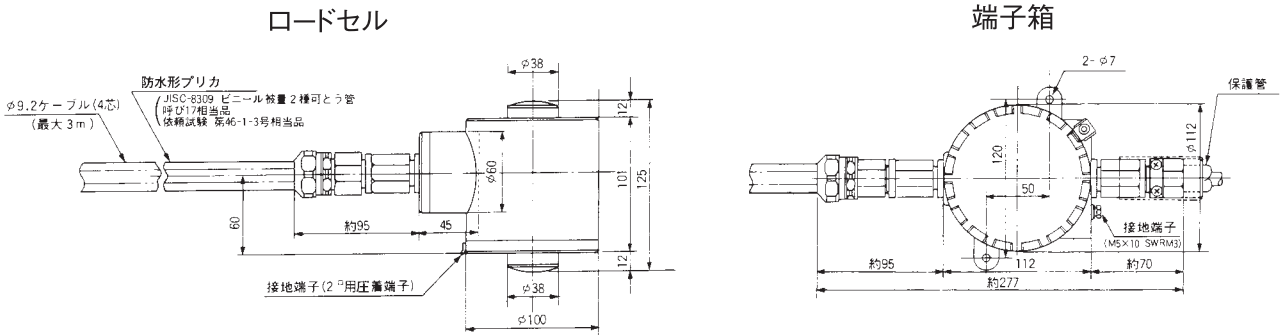

(注) ロードセルとロードセル端子箱間は3m以下とし防水ブリカを使用致します。

定格 50, 70t
(型式検定番号 第32141号)

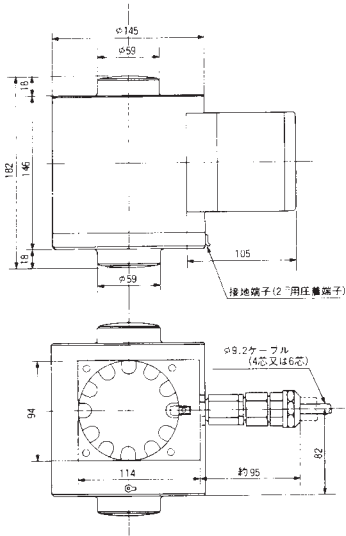

定格 100, 150t
(型式検定番号 第32094号)

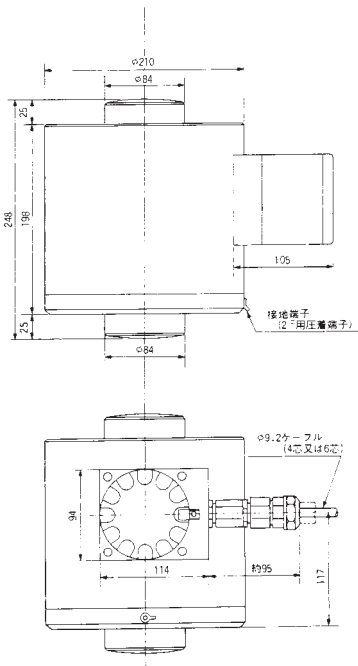

定格 200, 300t
(型式検定番号 第32095号)

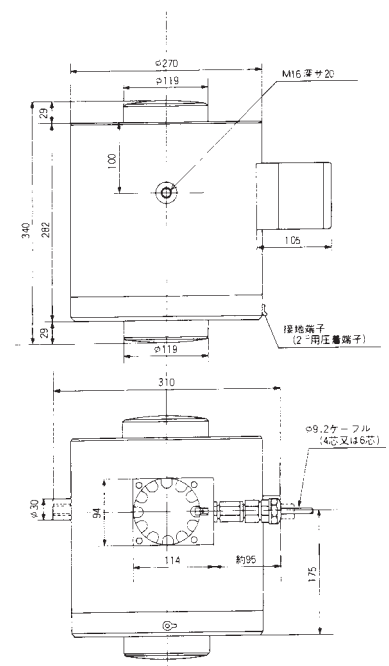

■注意事項

1. 周囲温度は60℃以下でご使用願います。
2. 接地抵抗は100Ω以下で接地願います。
3. 本ロードセルおよび端子箱寸法、構造については一切変更できません。

Please note:

1. Please operate with a temperature range below 60 degrees centigrade.
2. Please make the grounding resistance below 100 ohms.
3. Please make no alterations to the dimensions of the main load cell body, its terminal box or its configuration.

CD31

Capacity; 1, 2, 3, 5, 10t

小型ロープロフィールで耐スラスト負荷を考慮した独特の設計で、極めて狭い設置スペースへの適用が容易であるという特長を活かし、各種の中容量タンク、ホッパ等のレベル管理や安全装置の荷重検出に重宝なロードセルです。

With a special design in a compact low profile that takes into consideration endurance thrust load, this can be easily be adapted for extremely small spaces. While leveraging these features, this is a valuable load cell for load sensing of level control and safety equipment, such as all types of medium-capacity tanks and hoppers.



SPECIFICATIONS			Accuracy Class
			S級
PERFORMANCE			
定格荷重出力	Rated Output (R.O.)	mv/v	1.0±0.005
直線性(ヒステリシスを含む)	Linearity including hysteresis	% of R.O.	±0.2
繰返し性	Repeatability	% of R.O.	±0.1
クリープ(30分値)	Creep	% of R.O.	±0.05
クリープ回復性	Recovery	% of R.O.	±0.05
ELECTRICAL			
推奨印加電圧	Recommended excitation voltage	V ac or dc	10
最大印加電圧	Maximum excitation voltage	V ac or dc	15
零バランス	Zero balance	% of R.O.	±1
入力端子間抵抗	Input terminal resistance	Ohms	360±10
出力端子間抵抗	Output terminal resistance	Ohms	351±2
ケーブル長さ	Cable length	m	5
絶縁抵抗	Insulation resistance	Ohms	2000M
TEMPERATURE			
補償温度範囲	Compensated temperature range	℃	-10~+60
許容温度範囲	Safe temperature range	℃	-30~+80
出力の温度特性	Temperature effect on load	% of Reading/10℃	±0.05
零点の温度特性	Temperature effect on zero balance	% of R.O./5℃	±0.035
ADVERSE LOAD RATING			
許容過負荷	Safe overload	% of Rated Capacity	150
限界過負荷	Ultimate overload	% of Rated Capacity	300

(注) 避雷保護付の場合、外部からの測定した絶縁抵抗は100MΩ以上とします。

外形寸法図 DIMENSIONS

■外形寸法

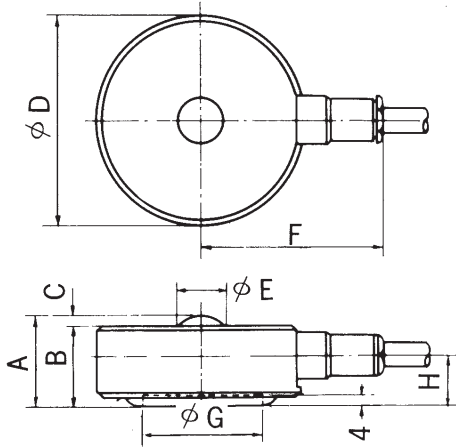

■結線図

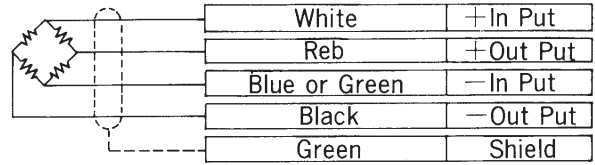

単位：mm

	A	B	C	ϕD	ϕE	F	ϕG	H
1.2.3t	42	37	5	105	25	96	65	23.5
5 t	54	49	5	120	25	103.5	73	31
10t	54	46	8	120	25	103.5	73	28

■取付図

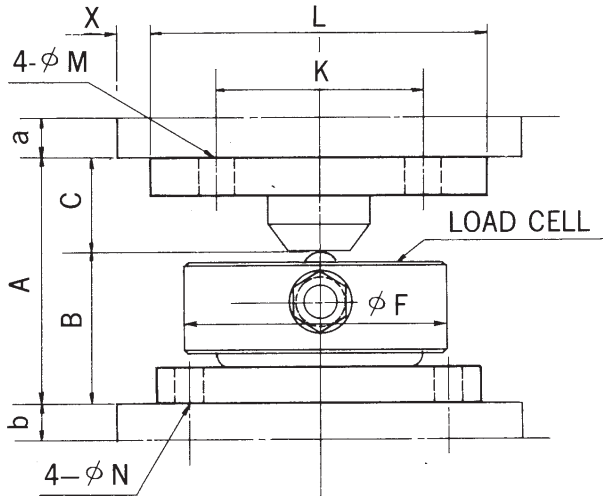

■各部寸法表

単位：mm

	1 t	2 t	3 t	5 t	10t
A	92	92	92	124	124
B	57	57	57	72	72
C	35	35	35	52	52
D	15	15	15	20	20
E	15	15	15	18	18
ϕF	105	105	105	120	120
G	49	49	49	56.5	56.5
H	125	125	125	150	200
J	100	100	100	110	140
K	100	100	100	110	110
L	125	125	125	140	170
ϕM	14	14	14	18	22
ϕN	14	14	14	14	14
ϕP	40	40	40	60	60
WT(kg)	6	6	6	11	14

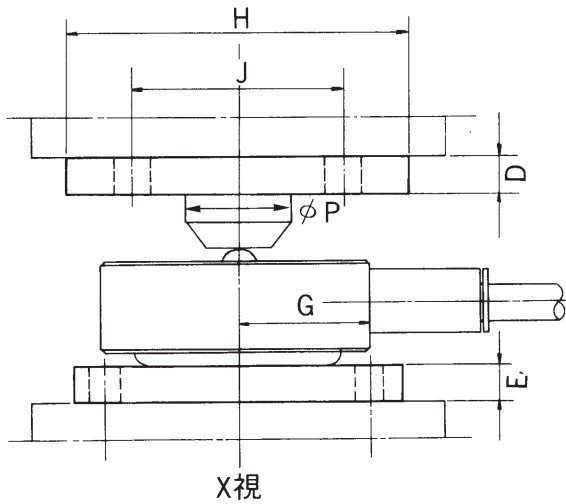

CR2

Capacity; 1, 2, 3, 5, 7t

Easily Installation
Hermetically Sealed

独特の弾性体構造からなる高性能圧縮ロードセルで、その優れた負荷特性、温度特性に加えて適度のコストパフォーマンスから各種の中容量電子式ホッパースケール、プラットフォームスケールなどに広く応用されます。

CR2はロードセル自身に自動調芯機能を持たせるダブルコンベックス方式を採用し、受圧部分を簡略化しています。

A high-performance compression load cell, due to its special elasticized body, this is widely used in all types of medium-capacity electronic hopper scales, platform scales and so on, thanks to its optimal cost performance, in addition to its outstanding load and temperature features.

The CR2 employs a double convex that gives it a self-centering function within the load cell itself, simplifying its pressure-receiving components.



SPECIFICATIONS			Accuracy Class	
			U 級	V 級
PERFORMANCE				
定格荷重出力	Reted Output (R.O.)	mv/v	3.0±0.003	3.0±0.003
直線性(ヒステリシスを含む)	Linearity including hysteresis	% of R.O.	±0.02	±0.03
繰返し性	Repeatability	% of R.O.	±0.01	±0.015
クリープ(30分値)	Creep	% of R.O.	±0.02	±0.03
クリープ回復性	Recovery	% of R.O.	±0.02	±0.03
ELECTRICAL				
推奨印加電圧	Recommended excitation voltage	V ac or dc	10	10
最大印加電圧	Maximum excitation voltage	V ac or dc	15	15
零バランス	Zero balance	% of R.O.	±1	±1
入力端子間抵抗	Input terminal resistance	Ohms	350±5	350±5
出力端子間抵抗	Output terminal resistance	Ohms	351±2	351±2
ケーブル長さ	Cable length	m	5	5
絶縁抵抗	Insulation resistance	Ohms	5000M	5000M
TEMPERATURE				
補償温度範囲	Compensated temperature range	℃	-10~+60	-10~+60
許容温度範囲	Safe temperature range	℃	-30~+80	-30~+80
出力の温度特性	Temperature effect on load	% of Reading/10℃	±0.01	±0.015
零点の温度特性	Temperature effect on zero balance	% of R.O./5℃	±0.01	±0.015
ADVERSE LOAD RATING				
許容過負荷	Safe overload	% of Rated Capacity	150	150
限界過負荷	Ultimate overload	% of Rated Capacity	300	300

(注) 避雷保護付の場合、外部からの測定した絶縁抵抗は100MΩ以上とします。

外形寸法図 DIMENSIONS

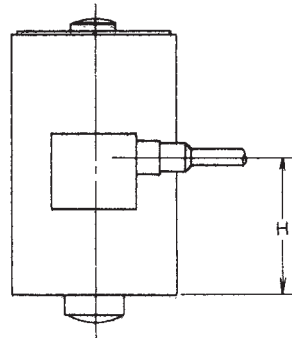
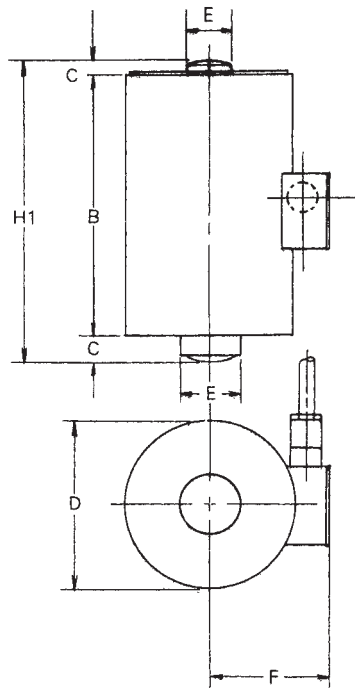

単位:mm

Cap.	H1	B	C	D	E	F	H
1 ^t	161.5	141.5	10	85	28	66.1	61.5
2	161.5	141.5	10	85	28	66.1	61.5
3	161.5	141.5	10	85	28	66.1	61.5
5	187.0	165.0	11	95	33	69.5	84.5
7	219.0	197.0	11	110	40	79.5	99.5

装着説明図 MOUNTING ACCESSORY

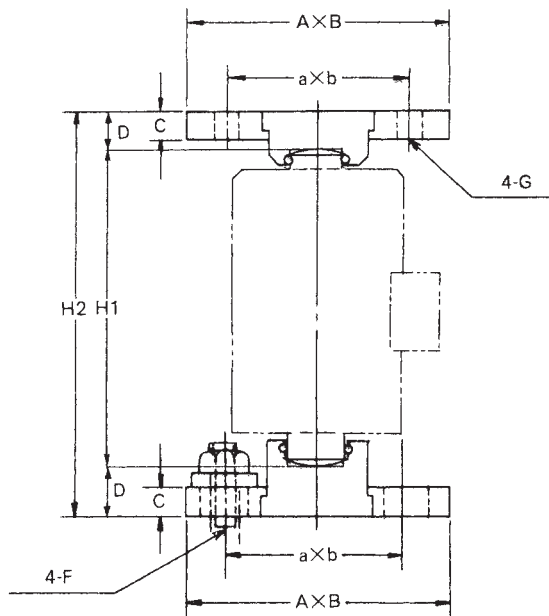

■ 結線図

ELECTRICAL TERMINATION

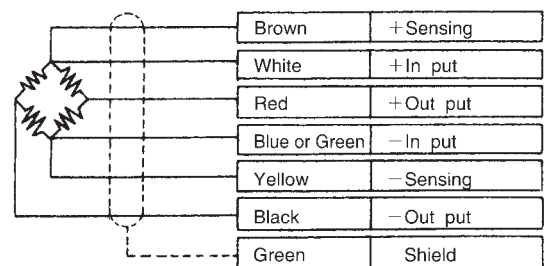

単位:mm

Cap.	A	a	B	b	C	D	F	G	H1	H2
1,2,3 ^t	150	100	130	80	12	23	M16	φ18	161.5	207.5
5	150	110	140	90	16	28	M16	φ18	187	243
7	200	140	170	110	19	29.5	M20	φ22	219	278

CA2

標準シリーズ確立 10~100t

電子はかりの設計、製作に長年の実績をもつ **Yamato** はその豊富な経験と最新の技術を導入して、計重機用の軸受形ロードセルを開発し、多数の納入実績を上げています。CA2シリーズは従来の圧縮形・引張形・カンチレバー・ビーム形とは異なり、装置内に組込み装置全体のコンパクト化を要求される計重機用として、広範囲にわたり応用ができるもので、計量システムとして技術的にも経済的にも最良の結果をお約束するものです。

Establishment of the Standard Series, with 10-100 tons

Yamato, which has many years of design and manufacturing experience, introduces its wealth of experience and newest technologies to develop a bearing-type load scale for weighing, which has enjoyed a large number of deliveries. The CA2 Series differs from the previous compressor, compression and cantilever types. As a scale that meets requirements that call for the compactness of all components, which are integrated inside the device, it can be employed throughout a vast range. As a weighing system, it promises to deliver the topmost results in terms of both technology and economy.

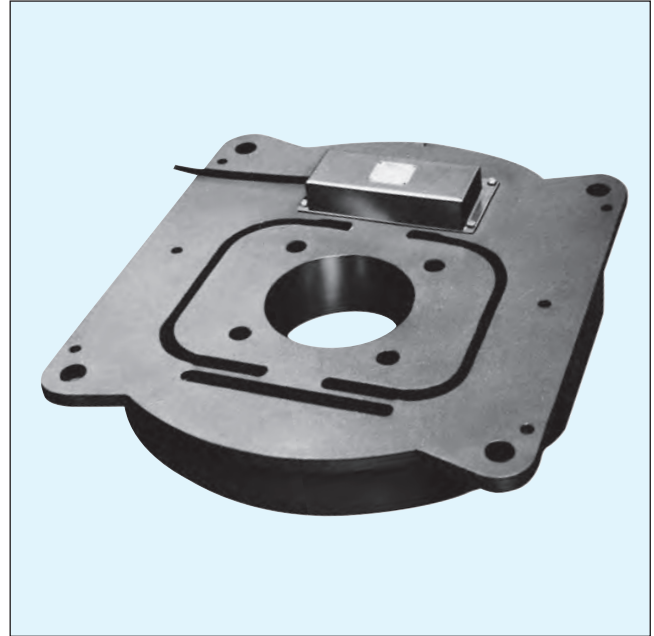

General Purpose

特長

- 構造物への組込、取付が簡単
- 横荷重に強い
- 精度と信頼性が非常に高い
- 完全密閉構造

Features

- Integrated structure and easy installation
- Good with lateral loads
- Extremely high levels of precision and reliability
- Hermetically sealed construction

SPECIFICATIONS			Accuracy Class
			H 級
PERFORMANCE			
定格出力	Reted Output (R.O.)	mv/v	1 ± 0.002
非直線性(ヒステリシスを含む)	Nonlinearity ^{☆1}	% of R.O.	0.1
繰返し性	Repeatability	% of R.O.	0.05
クリープ(30分値)	Creep ^{☆2}	% of R.O.	0.03
ELECTRICAL			
推奨印加電圧	Recommend excitation, voltage	V ac or dc	20
最大印加電圧	Maximum excitation, voltage	V ac or dc	30
零バランス	Zero balance	% of R.O.	± 1.0
入力端子間抵抗	Input terminal resistance	Ohms	700 ± 10
出力端子間抵抗	Output terminal resistance	Ohms	703 ± 2
ケーブル長さ	Cable length	m	5
絶縁抵抗	Insulation resistance	Ohms	2000M
TEMPERATURE			
補償温度範囲	Compensated temperature range	°C	- 10 ~ + 60
許容温度範囲	Safe temperature range	°C	- 30 ~ + 80
出力の温度特性	Temperature effect on load	% of Reading/10°C	± 0.05
零点の温度特性	Temperature effect on zero balance	% of R.O./10°C	± 0.07
ADVERSE LOAD RATING			
許容過負荷	Safe overload	% of Rated Capacity	150
限界過負荷	Ultimate overload	% of Rated Capacity	300

Note, ☆1 : Maximum deviation measured on increasing and decreasing loads.

☆2 : Change in output for 30 minutes at rated load.

外形寸法図 DIMENSIONS

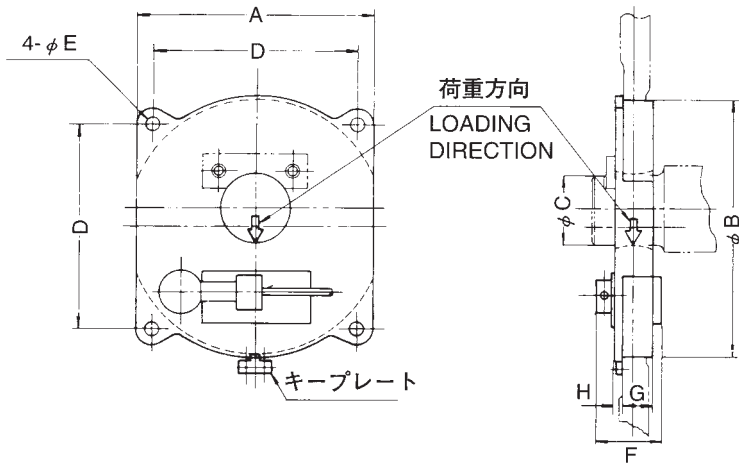

単位: mm

Cap.	A	φB	φC	D	φE	F	G	H	WT. (kg)
10 t	244	260	75	212	13.5	90	35	10	15
15	294	310	85	250	18	99	39	11	25
25	354	380	110	304	22	111	46	14	47
35	420	460	130	370	22	124	54	16	90
50	500	540	150	430	26	143	66	20	140
65	574	620	170	496	33	159	78	22	220
80	648	700	200	560	33	174	86	24	260
100	740	800	220	640	38	188	93	27	380

(注) 標準以外の定格容量についてはご相談下さい。

装着応用例 APPLICATION

フォーリングブロック組込式 FALLING BLOCK BUILT-IN TYPE

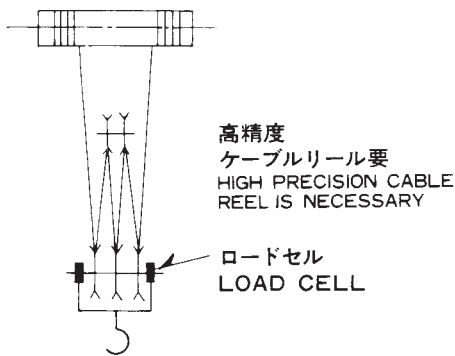

上部シーブ懸垂式 UPPER SHEAVE BLOCK HANGING TYPE

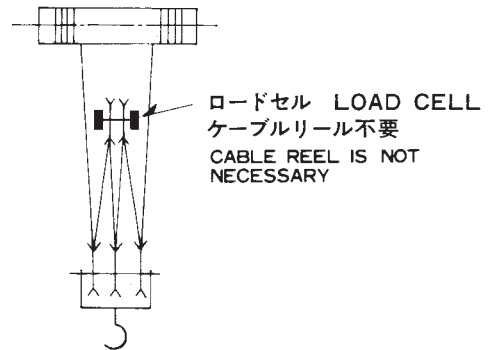

吊ビーム(レードルハンガ)組込式 HANGING BEAM (LADLE HANGER) BUILT-IN TYPE

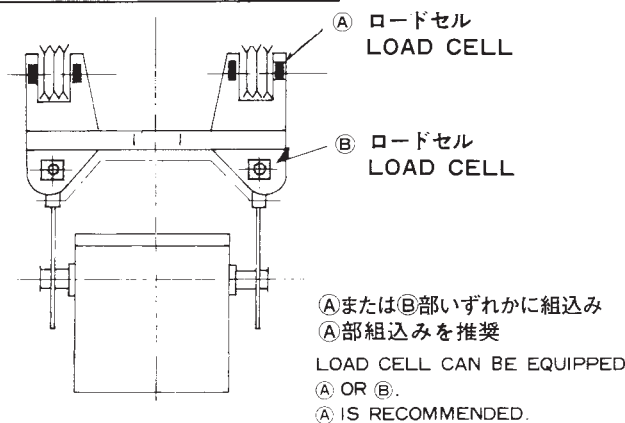

移動台車組込式 CARRIER BUILT-IN TYPE

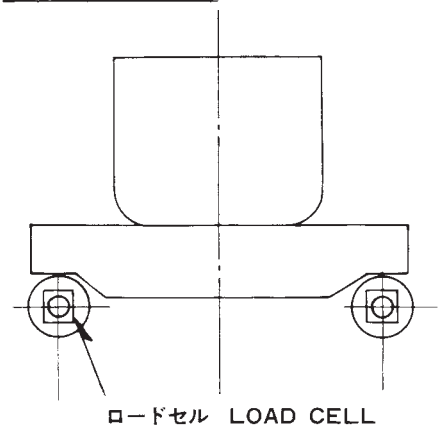

TC1

**Capacity; 10, 20, 30, 50,
70,100,150t**

**Easily Installation
Hermetically Sealed**

最も一般的な構造の大容量引張荷重ロードセルで、静または動的な荷重の測定用として0.1%以下の精度をもち、クレーンスケール、ホッパースケールその他の計測装置の力検出器として広い応用面で使用されております。

With the most general type of load cell, the large-capacity tension type, accuracy is within 0.1% for static as well as dynamic load measurements. It is used for a wide variety of applications as a force detector for measuring equipment, such as for crane scales and hopper scales.



SPECIFICATIONS			Accuracy Class
			0 級
PERFORMANCE			
定格荷重出力	Rated Output (R.O.)	mv/v	1.5±0.003
直線性(ヒステリシスを含む)	Linearity including hysteresis	% of R.O.	±0.06
繰返し性	Repeatability	% of R.O.	±0.05
クリープ(30分値)	Creep	% of R.O.	±0.03
クリープ回復性	Recovery	% of R.O.	±0.03
ELECTRICAL			
推奨印加電圧	Recommended excitation voltage	V ac or dc	10
最大印加電圧	Maximum excitation voltage	V ac or dc	15
零バランス	Zero balance	% of R.O.	±1
入力端子間抵抗	Input terminal resistance	Ohms	350±5
出力端子間抵抗	Output terminal resistance	Ohms	350±2
ケーブル長さ	Cable length	m	5
絶縁抵抗	Insulation resistance	Ohms	5000M
TEMPERATURE			
補償温度範囲	Compensated temperature range	℃	-10~+60
許容温度範囲	Safe temperature range	℃	-30~+80
出力の温度特性	Temperature effect on load	% of Reading/10℃	±0.05
零点の温度特性	Temperature effect on zero balance	% of R.O./5℃	±0.025
ADVERSE LOAD RATING			
許容過負荷	Safe overload	% of Rated Capacity	150
限界過負荷	Ultimate overload	% of Rated Capacity	300

(注) 避雷保護付の場合、外部からの測定した絶縁抵抗は100MΩ以上とします。

外形寸法図 DIMENSIONS

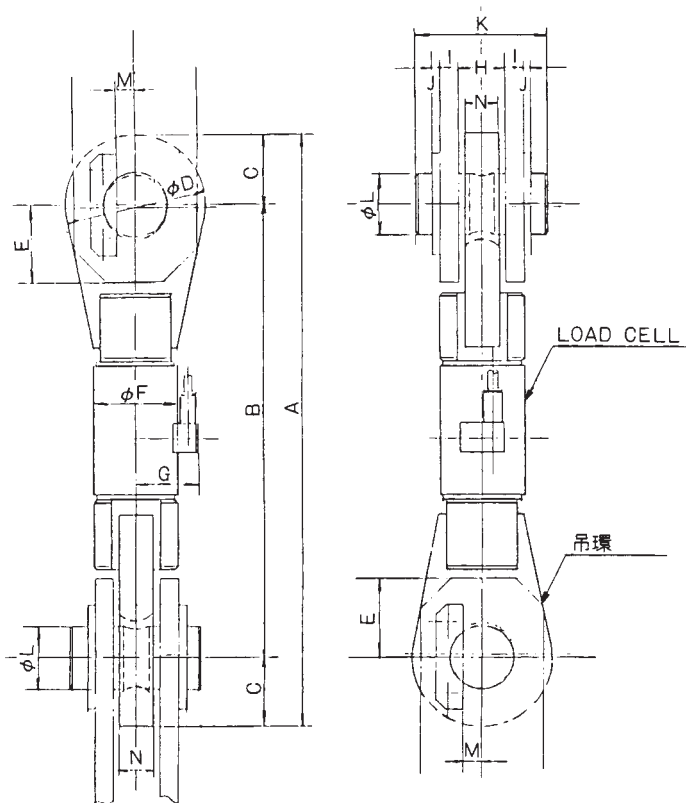

■つづみピン取合形

単位:mm

Cap.	A	B	C	φD	E	φF	G	H
10 ^t	567.5	433.5	67	141	75	96	76.5	50
20	785	602	91.5	192	105	111	81.5	65
30	971	742	114.5	240	110.5	139	98.5	80
50	1190	899	145.5	304	152.5	176	127.5	100
70	1416	1074	171	356	186	211	146.5	110
100	1659	1249	205	426	195	239	160.5	130
150	2158	1598	280	580	260	270	176.5	160

Cap.	I	J	K	φL	M	N	WT. (kg)
10 ^t	20	10	140	62	19	35	25
20	25	12	175	80	26	45	60
30	30	12	200	100	34	60	120
50	40	16	260	125	42.5	70	210
70	45	16	280	145	52.5	80	340
100	55	20	340	175	62.5	95	550
150	72	20	404	230	85	110	1090

(注) 吊環の取付角度は90度振る事も可能です。

T
C
1

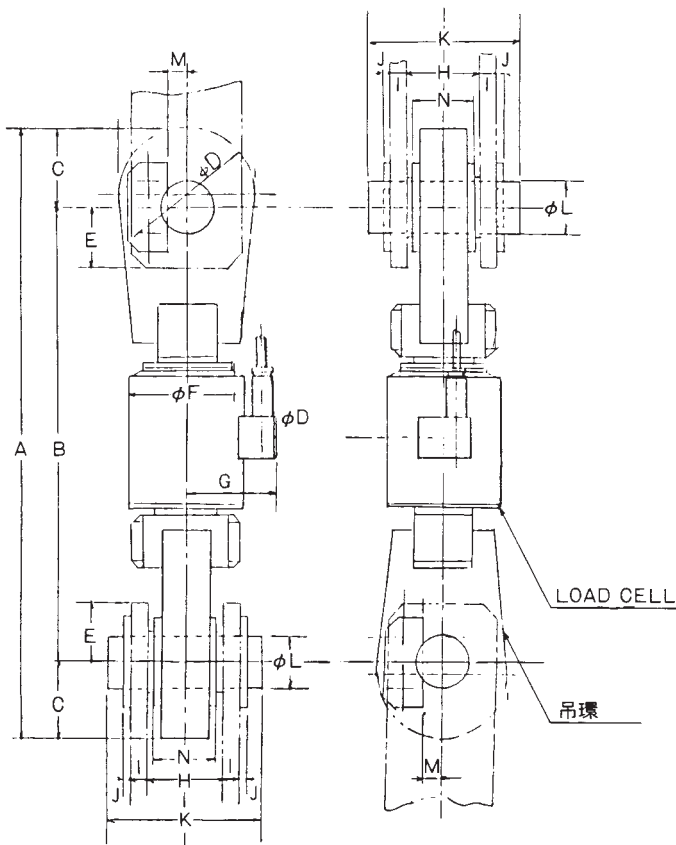

■ベアリング取合形

単位:mm

Cap.	A	B	C	φD	E	φF	G	H
10 ^t	599.5	433.5	83	140	61	96	76.5	75
20	828	602	113	194	83	111	81.5	100
30	1005	742	131.5	234	100	139	98.5	115
50	1243	899	172	300	132	176	127.5	155
70	1466	1074	196	350	150	211	146.5	170
100	1709	1249	230	420	175	239	160.5	185
150	2328	1598	365	620	220	270	176.5	225

Cap.	I	J	K	φL	M	N	WT. (kg)
10 ^t	19	6.8	151	55	17.5	62	25
20	28	9.8	206	75	25.5	83	60
30	32	13	241	85	28.5	93	120
50	40	13	297	115	41.5	129	210
70	50	17.2	353	130	45	143	340
100	60	17.2	388	150	55	158	550
150	70	20.6	466	190	65	188	1090

(注) 吊環の取付角度は90度振る事も可能です。

TP3

Capacity; 1, 2t

Easily Installation
Hermetically Sealed

独特な板状吊環方式の弾性体構造を持つ中容量引張形ローコストロードセルで、精密級のホッパー、タンクスケール等の計量装置で簡単な吊り金具のみで容易に装着でき、抜群の性能を発揮するため、その簡便さ、経済性が高く評価されております。

This is a medium-capacity tension low-cost load cell, whose construction is a unique plate-type with an elasticized body. Installation is easy requiring only a simple hoist for weighing equipment such as highly precise hoppers and tank scales. Its convenience and economy have been highly acclaimed, as it demonstrates exceptional performance.

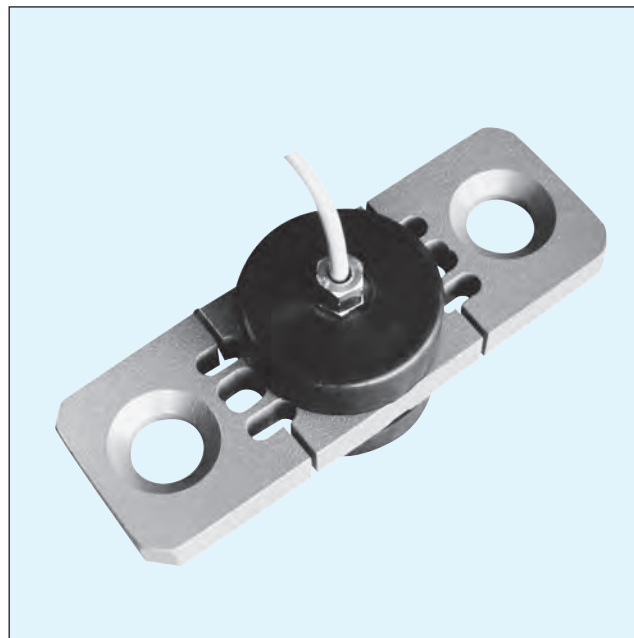

SPECIFICATIONS			Accuracy Class
			O 級
PERFORMANCE			
定格荷重出力	Reted Output (R.O.)	mv/v	2.0±0.04
直線性(ヒステリシスを含む)	Linearity including hysteresis	% of R.O.	±0.05
繰返し性	Repeatability	% of R.O.	±0.03
クリープ(30分値)	Creep	% of R.O.	±0.03
クリープ回復性	Recovery	% of R.O.	±0.03
ELECTRICAL			
推奨印加電圧	Recommended excitation voltage	V ac or dc	10
最大印加電圧	Maximum excitation voltage	V ac or dc	15
零バランス	Zero balance	% of R.O.	±1
入力端子間抵抗	Input terminal resistance	Ohms	405±15
出力端子間抵抗	Output terminal resistance	Ohms	351±3
ケーブル長さ	Cable length	m	5
絶縁抵抗	Insulation resistance	Ohms	5000M
TEMPERATURE			
補償温度範囲	Compensated temperature range	℃	-10~+60
許容温度範囲	Safe temperature range	℃	-30~+80
出力の温度特性	Temperature effect on load	% of Reading/10℃	±0.05
零点の温度特性	Temperature effect on zero balance	% of R.O./5℃	±0.025
ADVERSE LOAD RATING			
許容過負荷	Safe overload	% of Rated Capacity	150
限界過負荷	Ultimate overload	% of Rated Capacity	300

(注) 避雷保護付の場合、外部からの測定した絶縁抵抗は100MΩ以上とします。

外形寸法図 DIMENSIONS

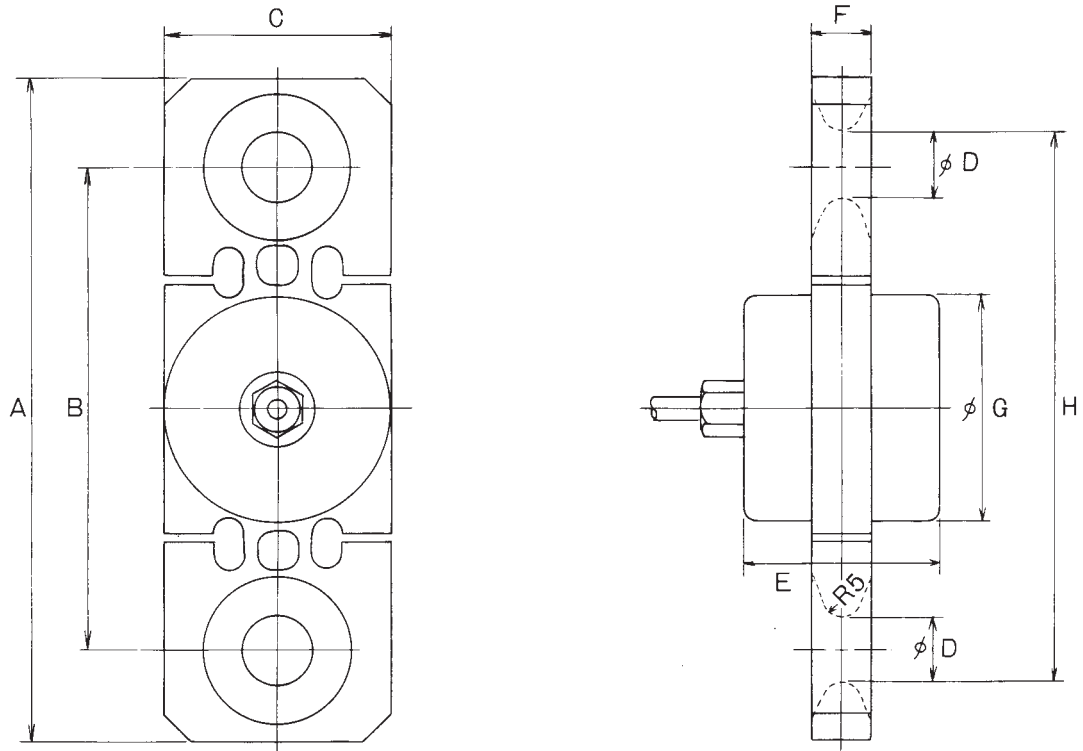

単位: mm

Cap.	A	B	C	ϕD	E	F	ϕG	H	WT. (kg)
1 ^t	176	128	59.2	20.3	52	16	62	148.3	1.3
2	190	136	64.2	24.3	52	16	62	160.3	1.5

応用例 APPLICATION

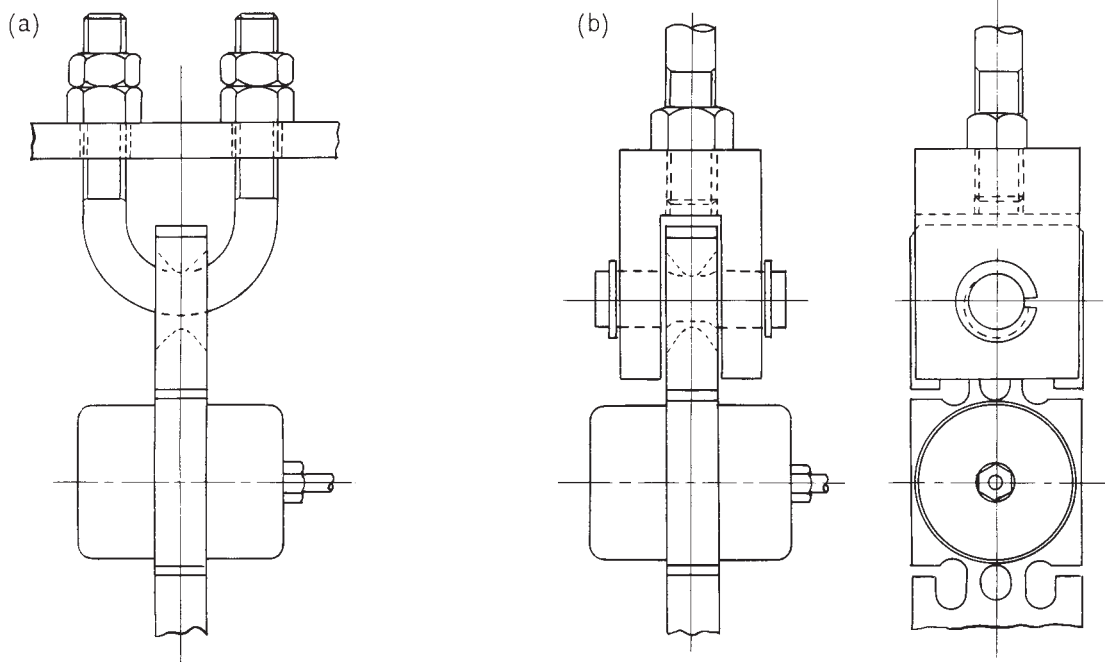

UR1

Capacity; 1, 2, 3, 5, 7t Tension/Compression Service

独特の弾性体構造を採用したこの高出力感度 (3mv/v) の引張/圧縮両用ロードセルは、静または動的な荷重の測定に適しており、正確で信頼性の高い力変換器として、各種の試験機や工業用はかりに幅広い応用分野で使用されております。

This tension-compression load cell with high output sensitivity (3mv/v) employs our unique elasticized body construction. It is suited for static as well as dynamic load measurements. As an accurate and highly reliable force transducer, it is being used in a wide range of applicable fields for various types of testing devices and industrial-use measurements.



SPECIFICATIONS			Accuracy Class
			V 級
PERFORMANCE			
定格荷重出力	Rated Output (R.O.)	mv/v	3.0±0.003
直線性(ヒステリシスを含む)	Linearity including hysteresis	% of R.O.	±0.03
繰返し性	Repeatability	% of R.O.	±0.015
クリープ(30分値)	Creep	% of R.O.	±0.03
クリープ回復性	Recovery	% of R.O.	±0.03
ELECTRICAL			
推奨印加電圧	Recommended excitation voltage	V ac or dc	10
最大印加電圧	Maximum excitation voltage	V ac or dc	15
零バランス	Zero balance	% of R.O.	±1
入力端子間抵抗	Input terminal resistance	Ohms	350±5
出力端子間抵抗	Output terminal resistance	Ohms	351±2
ケーブル長さ	Cable length	m	5
絶縁抵抗	Insulation resistance	Ohms	5000M
TEMPERATURE			
補償温度範囲	Compensated temperature range	℃	-10~+60
許容温度範囲	Safe temperature range	℃	-30~+80
出力の温度特性	Temperature effect on load	% of Reading/10℃	±0.015
零点の温度特性	Temperature effect on zero balance	% of R.O./5℃	±0.015
ADVERSE LOAD RATING			
許容過負荷	Safe overload	% of Rated Capacity	150
限界過負荷	Ultimate overload	% of Rated Capacity	300

(注) 避雷保護付の場合、外部からの測定した絶縁抵抗は100MΩ以上とします。

外形寸法図 DIMENSIONS

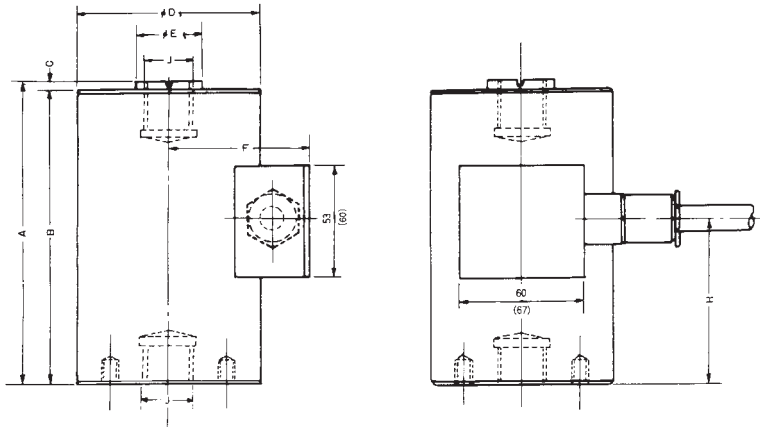

(注)
 () 内寸法は 5,7t 用
 NOTE:
 DIMENSIONS IN PARENTHESES
 APE FOR 5&7t

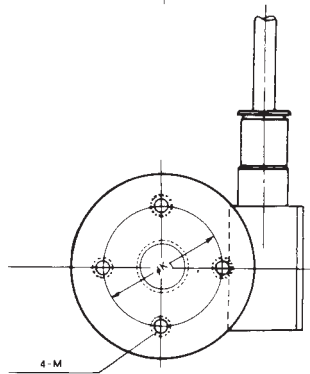

単位:mm

Cap.	A	B	C	φD	φE	F	H	J	φK	M	WT. (kg)
1 t	151.5	146.5	5	85	30	66.1	66.5	M24 深サ20	65	M8 深サ12	4
2	151.5	146.5	5	85	30	66.1	66.5	M24 深サ20	65	M8 深サ12	4
3	151.5	146.5	5	85	30	66.1	66.5	M24 深サ20	65	M8 深サ12	4
5	176.0	171.5	5	95	37	69.7	90.5	M30 深サ24	75	M8 深サ12	6
7	204.0	198.0	6	110	43	79.5	100.5	M36 深サ35	85	M8 深サ12	8

装着方法 LODING RECOMENDATIONS

(1) ピンヒンジの応用例
 APPLICATIONS OF
 PIN HINGE

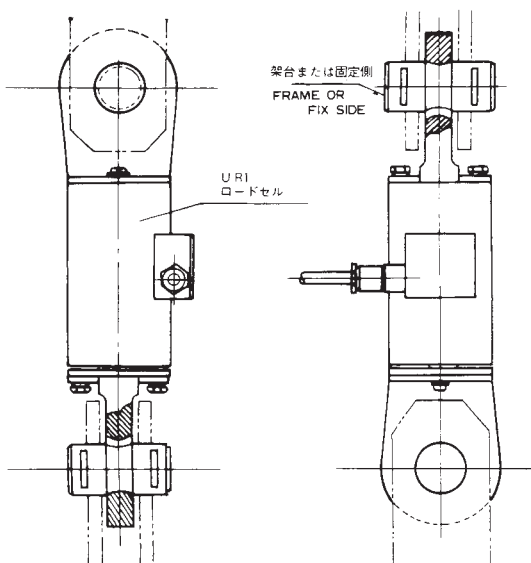

(2) U環ヒンジの応用例
 APPLICATIONS OF
 U-RING HINGE

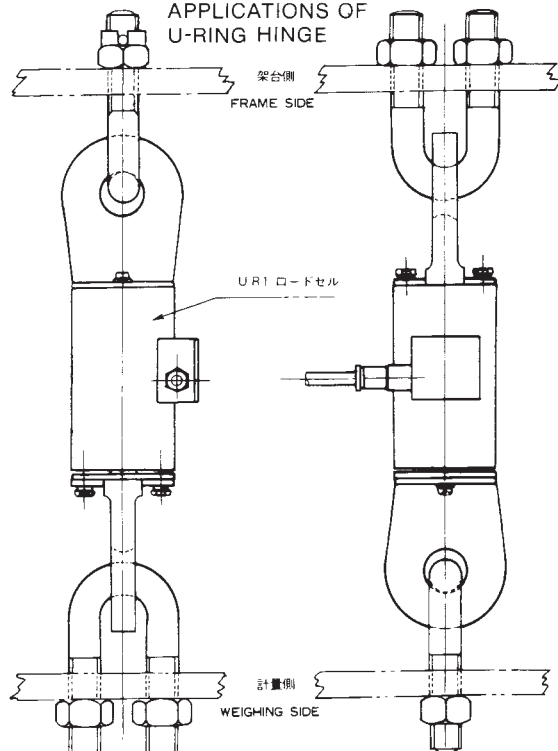

US3

**Capacity; 100 · 200 · 300 · 500
1000 and 2000kg**

High accuracy 0.05%
Easy Installation
Environmentally Resistant
Low Cost.
Tension/Compression Service

荷重の力作用軸線が常に弾性体中心を通り、偏芯偏荷重の誤差要因の影響を受けにくい独特の構造を持つロードセルで、圧縮・引張りの両方において高精度の計量が可能です。小形で特別な付加機構を必要としないため、種々の計量装置に簡単に取付ができ、広い応用範囲で計量を可能にします。

A load cell with a unique construction that rebuffs eccentric and unbalanced loads, and the axis line for load action routinely passes through the center of the elasticized body. It is capable of making highly precise measurements in both compression and tension. As it is compact and doesn't require special additional mechanisms, various types of measurement devices can be installed easily, and measurements are possible in a wide variety of applications.



SPECIFICATIONS			Accuracy Class
			H 級
PERFORMANCE			
定格出力	Reted Output (R.O.)	mv/v	2.0±0.01 ^{☆3}
非直線性(ヒステリシスを含む)	Nonlinearity ^{☆1}	% of R.O.	±0.05
繰返し性	Repeatability	% of R.O.	±0.03
クリープ(30分値)	Creep ^{☆2}	% of R.O.	±0.03
ELECTRICAL			
推奨印加電圧	Recommend excitation, voltage	V ac or dc	10
最大印加電圧	Maximum excitation, voltage	V ac or dc	15
零バランス	Zero balance	% of R.O.	±1.0
入力端子間抵抗	Input terminal resistance	Ohms	410±5
出力端子間抵抗	Output terminal resistance	Ohms	351±2
ケーブル長さ	Cable length	m	2
絶縁抵抗	Insulation resistance	Ohms	5000M
TEMPERATURE			
補償温度範囲	Compensated temperature range	°C	-10~+50
許容温度範囲	Safe temperature range	°C	-30~+80
出力の温度特性	Temperature effect on load	% of Reading/10°C	±0.03
零点の温度特性	Temperature effect on zero balance	% of R.O./10°C	±0.03
ADVERSE LOAD RATING			
許容過負荷	Safe overload	% of Rated Capacity	150
限界過負荷	Ultimate overload	% of Rated Capacity	300

Note, ☆ 1 : Maximum deviation measured on increasing and decreasing load.

☆ 2 : Change in output for 30 minutes at rated load.

☆ 3 : Better calibration accuracy is available on request.

外形寸法図 DIMENSIONS

■外形寸法 DIMENSIONS (圧縮形)

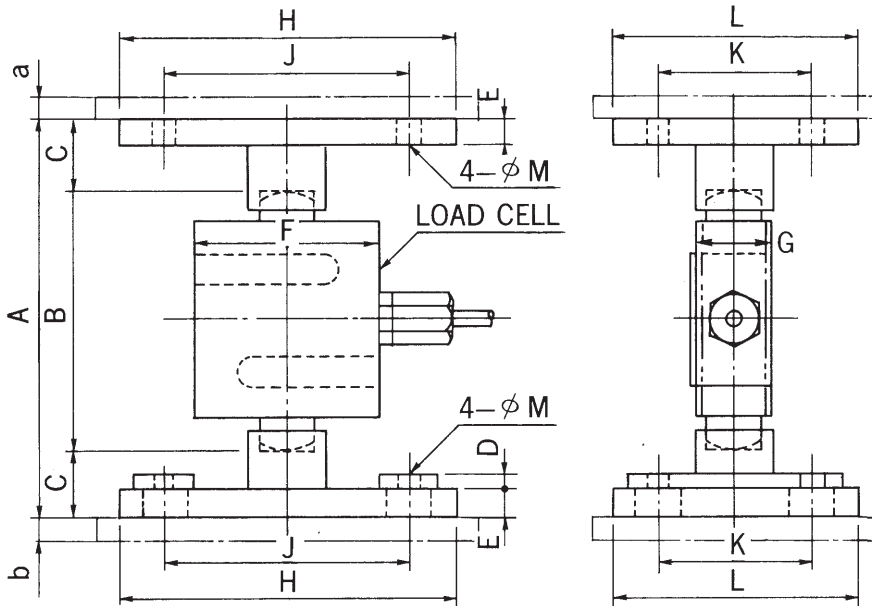

	100, 200kg	300, 500kg	1,2 t
A	130	150	190
B	87	105	140
C	21.5	22.5	25
D	4.5	6	6
E	9	12	12
F	70	90	130
G	35	38	60
H	110	130	150
J	80	100	100
K	50	50	80
L	80	80	130
φ M	10	14	18
WT(kg)	3	4	6

■外形寸法 DIMENSIONS (引張形)

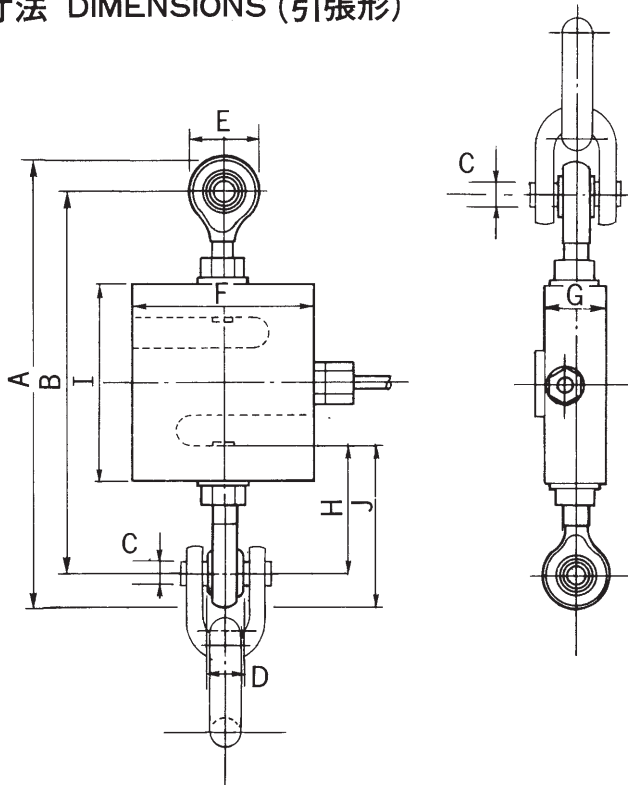

	100, 200kg	100, 500kg	1,2t
A	152	180	305
B	130	155	250
φ C	8	12	25
D	12	16	20
E	22	30	55
F	70	90	130
G	35	38	60
H	42	54	94
I	70	85	125
J	53	69	124
WT(kg)	3	4	6

■結線図 ELECTRICAL TERMINATION

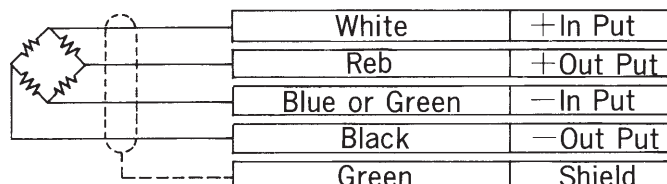

US4

標準シリーズ確立 10t～100t

電子はかりの設計、製作に長年の実績をもつ **Yamato** はその豊富な経験と最新の技術を導入して、軸形ロードセルを開発し、多数の納入実績を上げています。

US4シリーズは従来の圧縮形・引張形・カンチレバー・ビーム形とは異なり装置内に組込み装置全体のコンパクト化を要求される、荷重検出器として、広範囲にわたり応用できるもので、技術的にも経済的にも最良の結果をお約束するものです。

Establishment of the Standard Series, with 10-100 tons

Yamato, which has many years of design and manufacturing experience, introduces its wealth of experience and newest technologies. It has developed a bearing-type load scale for weighing, which boasts a large number of deliveries.

The US4 Series differs from the previous compressor, tension and cantilever types. As a scale that meets requirements that call for the compactness of all components, which are integrated inside the device, it can be employed throughout a vast range. As a load-sensing system, it promises to deliver the topmost results in terms of both technology and economy.

特長

- 構造物への組込、取付が簡単
- コンパクトな組込が可能
- 横荷重に強い
- 完全密閉構造

Features

- Integrated structure and easy installation
- Good with lateral loads
- Extremely high levels of precision and reliability
- Hermetically sealed construction



SPECIFICATIONS			Accuracy
PERFORMANCE			
定格出力	Rated Output (R.O.)	mv/v	1±0.01
非直線性(ヒステリシスを含む)	Nonlinearity ^{☆1}	% of R.O.	±1~2
繰返し性	Repeatability	% of R.O.	0.3
クリープ(30分値)	Creep ^{☆2}	% of R.O.	0.05
ELECTRICAL			
推奨印加電圧	Recommend excitation, voltage	V ac or dc	20
最大印加電圧	Maximum excitation, voltage	V ac or dc	30
零バランス	Zero balance	% of R.O.	±1.0
入力端子間抵抗	Input terminal resistance	Ohms	700±10
出力端子間抵抗	Output terminal resistance	Ohms	703±3
ケーブル長さ	Cable length	m	5
絶縁抵抗	Insulation resistance	Ohms	2000M
TEMPERATURE			
補償温度範囲	Compensated temperature range	°C	-10~+60
許容温度範囲	Safe temperature range	°C	-30~+80
出力の温度特性	Temperature effect on load	% of Reading/10°C	±0.25
零点の温度特性	Temperature effect on zero balance	% of R.O./10°C	±0.07
ADVERSE LOAD RATING			
許容過負荷	Safe overload	% of Rated Capacity	150
限界過負荷	Ultimate overload	% of Rated Capacity	300

Note, ☆ 1 : Maximum deviation measured on increasing and decreasing load.

☆ 2 : Change in output for 20 minutes at rated load.

外形寸法図 DIMENSIONS

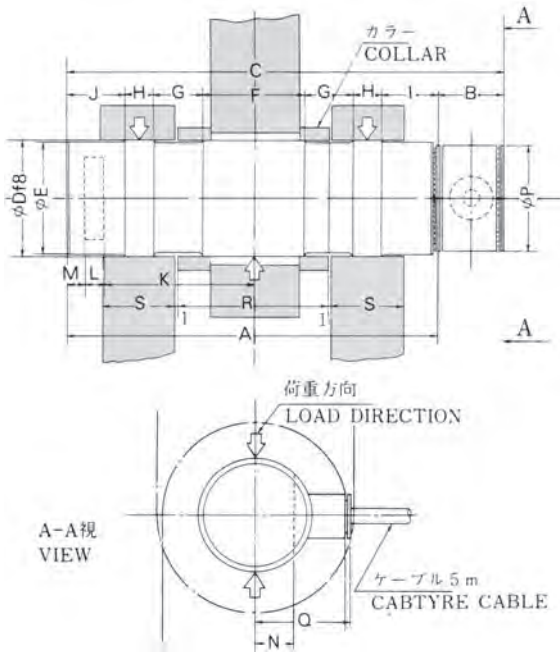

単位:mm

Cap.	A	B	C	φD	φE	F	G	H	I	J
10 ^t	160	37.5	197.5	50	48	46	22	10	25	25
20	220	35	255	70	68	64	30	14	34	34
30	256	35	291	85	83	78	37	17	35	35
50	326	35	361	105	103	96	46	21	48	48
70	382	35	417	125	123	114	56	25	53	53
100	458	35	493	150	147	138	66	30	64	64

Cap.	K	L	M	N	φP	Q	R	S	WT. (kg)
10 ^t	64.5	8.5	7	15	45	47	68	30	3
20	85	14	11	23	70	59	103	33	8
30	102	14	12	28.5	70	59	131	36	13
50	129	18	16	36.5	70	51	157	50	24
70	155	18	18	42.5	70	49	189	60	38
100	185	22	22	55	70	45	227	71	65

装着応用例 APPLICATION

エコライザーシーブ軸
EQUALIZER SHEAVE PIN

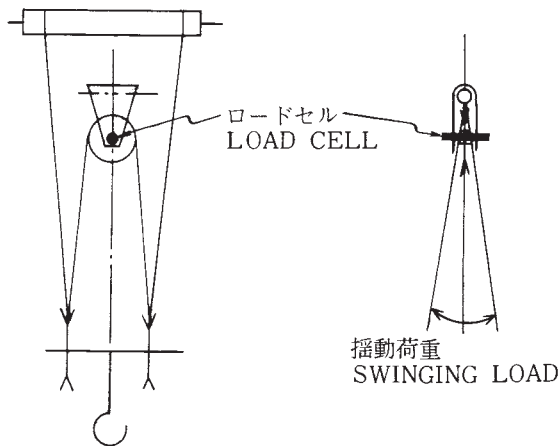

ロープエンド
ROPE END

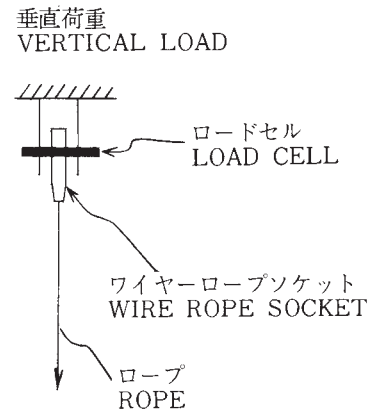

コンテナクレーン 偏荷重検出
DEVIATION LOAD DETECTOR
FOR CONTAINER CRANE

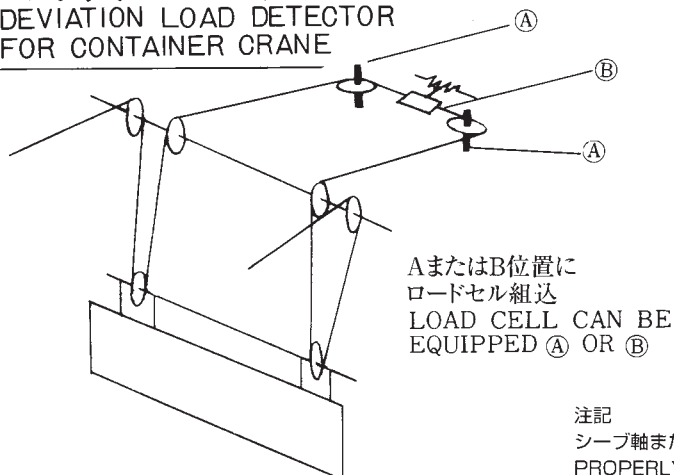

鎖張力検出
CHAIN TENSION DETECTOR

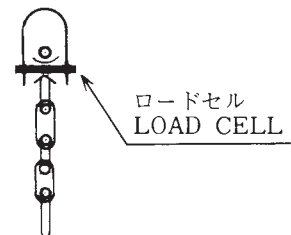

注記

シーブ軸または、回転部分に使用する場合、給油に注意下さい。

PROPERLY LUBRICATE OIL TO SHEAVE PIN AND ROTATING PORTION

UB1

**Capacity; 20, 30, 50, 100, 200,
500, 1000, 2000kg**

**Cantilever Beams
Hermetically Sealed**

カンチレバービーム形であり、水平に設置するだけで簡単に縦方向の力が検出でき、形状が小さく取付が容易であることに加えて、超高性能の負荷特性という優れた特長をもつことから、薄形プラットフォームスケールやコンベヤスケールに、また槓桿併用の各種はかりの計量部力検出器として幅広い応用面を誇っているロードセルです。

ゲージ感歪部はステンレススチールベローで覆い、その接合部を溶接した完全金属シール構造で内部には不活性ガスを封入して周囲環境の悪い場所での使用に耐えるように設計しています。

This is a cantilever-beam model. Not only is it installed horizontally, but it can easily detect longitudinal forces. In addition to being easy to install due to its compact size, it possesses outstanding load characteristics that provide ultra-high performance. Thus as a measurement force detector in thin platform scales and conveyance scales as well as in various types of combined lever measuring instruments, this is a load cell that boasts a wide range of applications.

The gauge feeling elliptical part is covered in stainless steel bellows. Through a hermetically metal sealed construction where the joint is welded, inert gases are sealed inside. This is designed to stand up to use in bad environments.



SPECIFICATIONS			Accuracy Class	
			U 級	V 級
PERFORMANCE				
定格荷重出力	Reted Output (R.O.)	mv/v	1.8±0.002	1.8±0.005
直線性(ヒステリシスを含む)	Linearity including hysteresis	% of R.O.	±0.02	±0.03
繰返し性	Repeatability	% of R.O.	±0.01	±0.015
クリープ(30分値)	Creep	% of R.O.	±0.02	±0.03
クリープ回復性	Recovery	% of R.O.	±0.02	±0.03
ELECTRICAL				
推奨印加電圧	Recommended excitation voltage	V ac or dc	10	10
最大印加電圧	Maximum excitation voltage	V ac or dc	15	15
零バランス	Zero balance	% of R.O.	±1	±1
入力端子間抵抗	Input terminal resistance	Ohms	395±10	395±10
出力端子間抵抗	Output terminal resistance	Ohms	351±2	351±2
ケーブル長さ	Cable length	m	2	2
絶縁抵抗	Insulation resistance	Ohms	5000M	5000M
TEMPERATURE				
補償温度範囲	Compensated temperature range	℃	-10~+60	-10~+60
許容温度範囲	Safe temperature range	℃	-30~+80	-30~+80
出力の温度特性	Temperature effect on load	% of Reading/10℃	±0.01	±0.015
零点の温度特性	Temperature effect on zero balance	% of R.O./5℃	±0.01	±0.015
ADVERSE LOAD RATING				
許容過負荷	Safe overload	% of Rated Capacity	150	150
限界過負荷	Ultimate overload	% of Rated Capacity	300	300

(注) 避雷保護付の場合、外部からの測定した絶縁抵抗は100MΩ以上とします。

外形寸法図 DIMENSIONS

■20・30・50・100・200・300kg 重量；約2.5kg

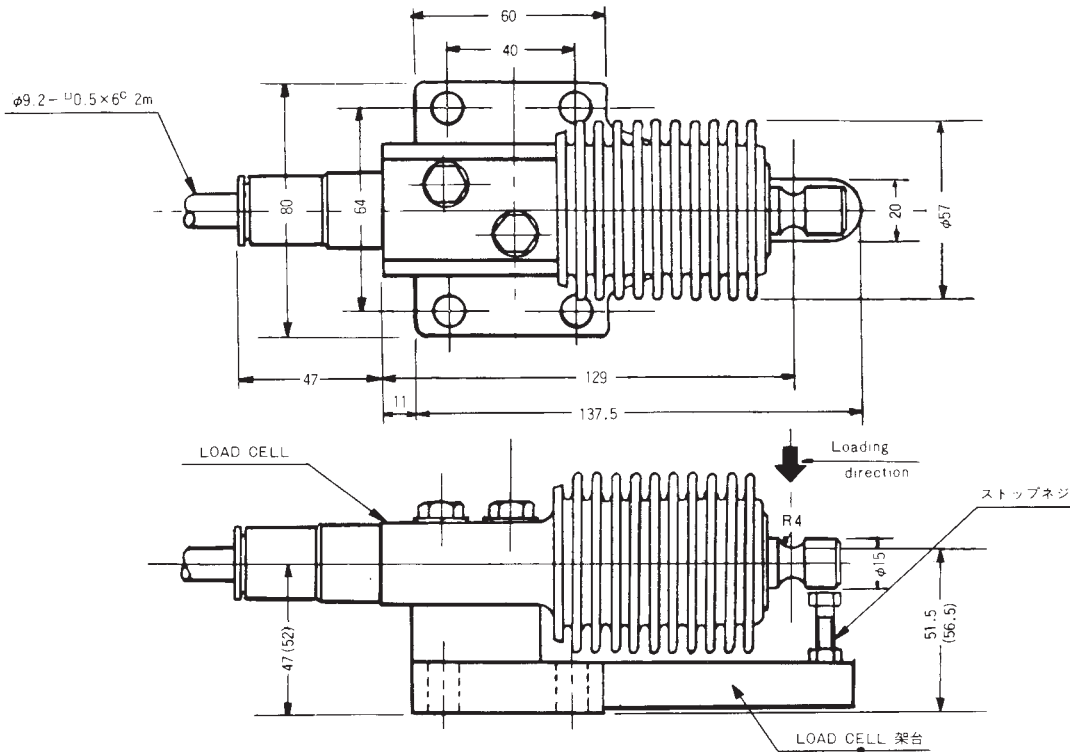

- (注) 1. ロードセルとロードセル架台は必ず一体で取扱い、絶対に分離しないように願います。
 2. 過荷重防止ストップネジは120%荷重にて接触するよう調整して下さい。
 3. 荷重着力部は負荷を安定させるようにR3以下の小さいRで荷重を負荷して下さい。
 4. このロードセルは片荷重用として、負荷時に必ずストップが接触する方向に荷重を負荷して下さい。
 5. ()内寸法は100kg, 200kg, 300kg用を示します。

- 1) The load cell and load-cell cradle are always handled as a single unit, so please never separate the two.
 2) Please adjust the overload prevention stop-screw so that it makes contact at a 120% load.
 3) To stabilize the load, please adjust the load attachment component for a load of small R, less than R3.
 4) With this load cell during loading, please always set the load in the direction of where the stopper makes contact, for one-way load use.
 5) The dimensions inside the brackets indicate use for 100kg, 200kg and 300kg.

■500・1000・2000kg 重量；約3kg

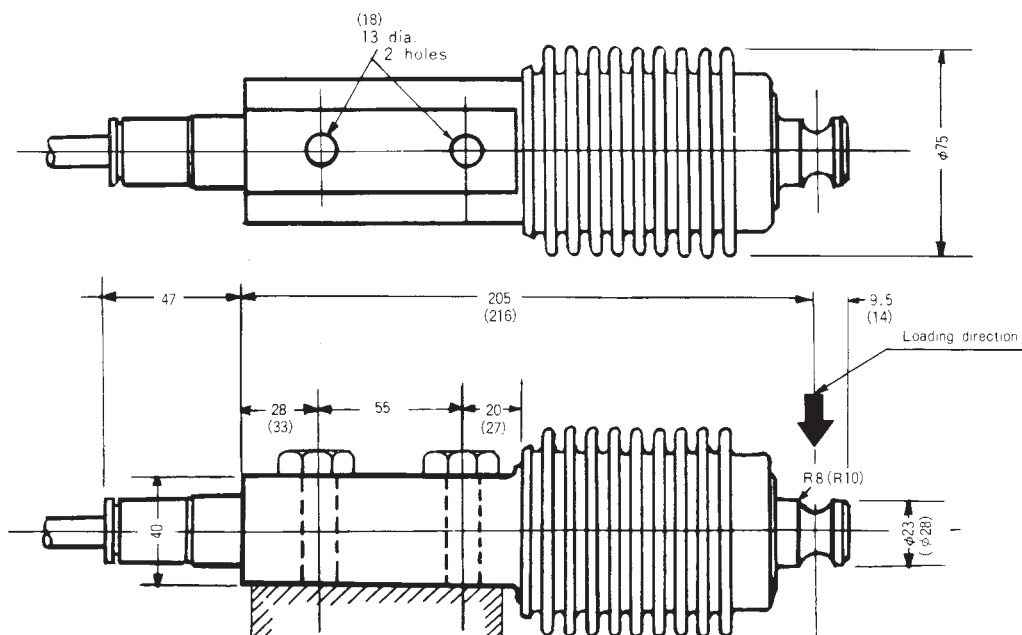

- (注) 1. ()内寸法は2000kg用を示します。

UB2

**Capacity; 5, 10, 20, 30, 50,
100, 200, 300kg**

**Cantilever Beams
Hermetically Sealed**

完全金属シールに不活性ガス封入で、小容量の超高精度計量を可能にした、高力アルミ弾性体カンチレバービーム形ロードセルです。

小形、軽量で取付けが容易であり、特に槓桿併用の各種はかりの力検出器として優れた特性を発揮します。

This cantilever-type load cell has a high-power aluminum elasticized body and enables highly precise large-capacity measurements, with inert gases sealed completely in metal. Installation is easy, thanks to its compact size and light weight. It exhibits outstanding features as a force detector for various types of measuring instruments for use with lever combinations.

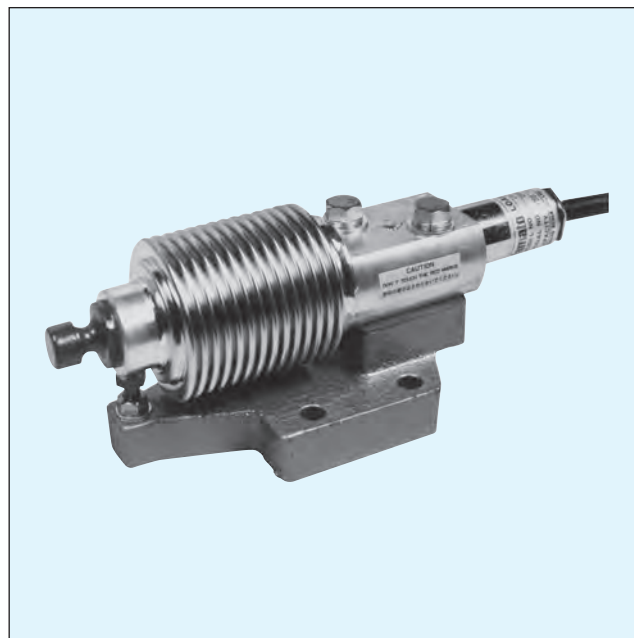

SPECIFICATIONS			Accuracy Class	
			U 級	V 級
PERFORMANCE				
定格荷重出力	Rated Output (R.O.)	mv/v	2.0*	2.0*
直線性(ヒステリシスを含む)	Linearity including hysteresis	% of R.O.	±0.02	±0.03
繰返し性	Repeatability	% of R.O.	±0.01	±0.015
クリープ(30分値)	Creep	% of R.O.	±0.02	±0.03
クリープ回復性	Recovery	% of R.O.	±0.02	±0.03
ELECTRICAL				
推奨印加電圧	Recommended excitation voltage	V ac or dc	10	10
最大印加電圧	Maximum excitation voltage	V ac or dc	15	15
零バランス	Zero balance	% of R.O.	±1	±1
入力端子間抵抗	Input terminal resistance	Ohms	350±10	350±10
出力端子間抵抗	Output terminal resistance	Ohms	351±2	351±2
ケーブル長さ	Cable length	m	2	2
絶縁抵抗	Insulation resistance	Ohms	5000M	5000M
TEMPERATURE				
補償温度範囲	Compensated temperature range	°C	-10~+60	-10~+60
許容温度範囲	Safe temperature range	°C	-30~+80	-30~+80
出力の温度特性	Temperature effect on load	% of Reading/10°C	±0.01	±0.015
零点の温度特性	Temperature effect on zero balance	% of R.O./5°C	±0.01	±0.015
ADVERSE LOAD RATING				
許容過負荷	Safe overload	% of Rated Capacity	150	150
限界過負荷	Ultimate overload	% of Rated Capacity	300	300

(注) 避雷保護付の場合、外部からの測定した絶縁抵抗は100MΩ以上とします。

*出力校正:5・10kg…±0.03mv/v, 20kg…±0.015mv/v,
30~300kg…±0.006mv/v

外形寸法図 DIMENSIONS

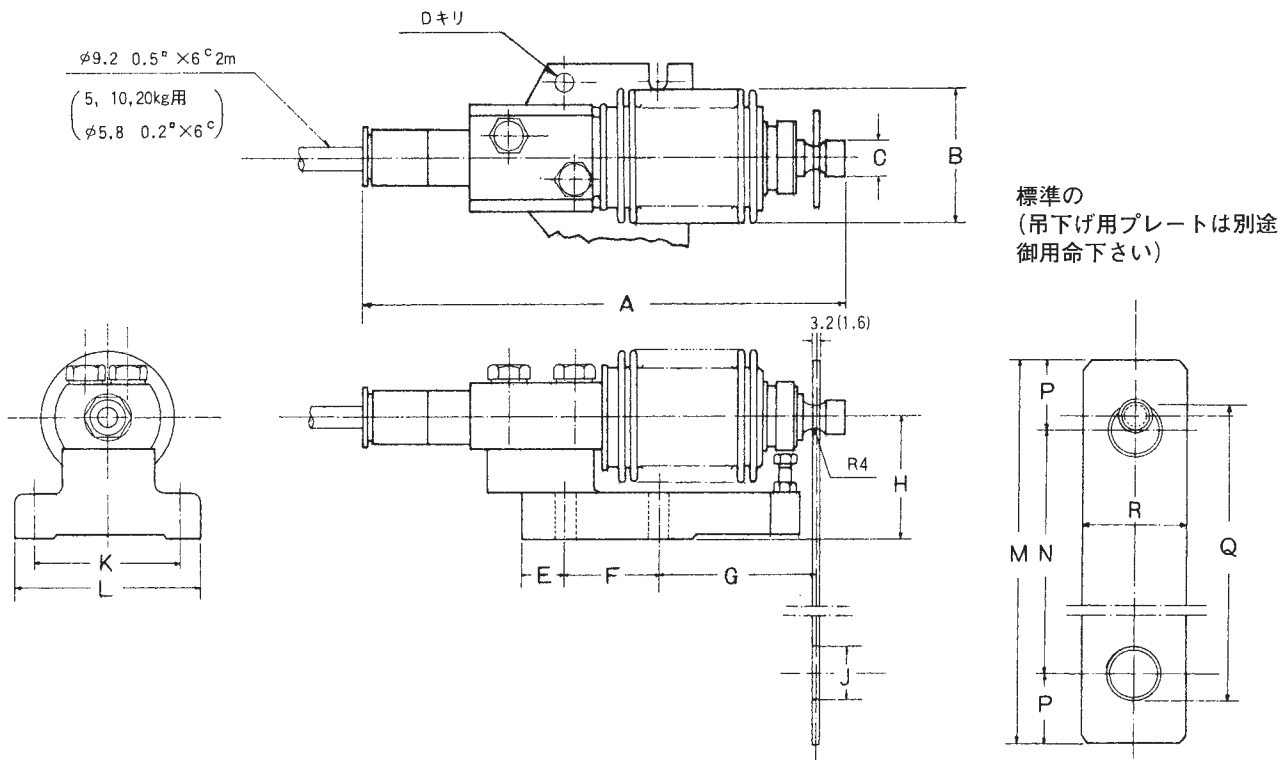

単位: mm

Cap.	A	B	C	D	E	F	G	H	J	K	L	M	N	P	Q	R
5,10,20kg	170	$\phi 41$	$\phi 10$	$\phi 7$	7	35	90	35	$\phi 10.5$	45	60	72	50	11	60.5	22
30,50kg	206.3	$\phi 57$	$\phi 15$	$\phi 9$	18	40	68	47	$\phi 16$	64	80	195.5	149.5	23	165.5	40
100,200,300kg	206.3	$\phi 57$	$\phi 15$	$\phi 9$	18	40	68	52	$\phi 21$	64	80	326.5	265.5	30.5	286.5	45

UHB 61/62/63

**Capacity; 50, 100, 250, 500,
1000, 2000kg**

High accuracy 0.02%
Unique humidity-resistant
protective coating
Long-term stability

The most cost effective method for weighing
bigger loads on bigger platforms.

この種のパラレログラムロードセルとしては比較的大きな横剛性を持たせた設計で、幅広い容量範囲と卓越した負荷特性、独特の工夫をこらした耐湿構造を有することから、小中容量の薄形台秤に最適のロードセルとして広く利用されています。

This has a design that gives comparatively high lateral stiffness for this type of parallelogram load cell. Due to its humidity-resistant construction that takes advantage of its wide-ranging capacity, outstanding load characteristics and unique innovations, this is widely used as the optimal load cell for small-capacity thin-type platform scales.



SPECIFICATIONS			Accuracy Class
			U 級
PERFORMANCE			
定格出力	Reted Output (R.O.)	mv/v	2.0±0.1
非直線性(ヒステリシスを含む)	Nonlinearity ^{☆1}	% of R.O.	0.02
繰返し性	Repeatability	% of R.O.	0.01
クリープ(30分値)	Creep ^{☆2}	% of R.O.	0.02
ELECTRICAL			
推奨印加電圧	Recommend excitation, voltage	V ac or dc	10
最大印加電圧	Maximum excitation, voltage	V ac or dc	15
零バランス	Zero balance	% of R.O.	2
入力端子間抵抗	Input terminal resistance	Ohms	406±15
出力端子間抵抗	Output terminal resistance	Ohms	351±3
ケーブル長さ	Cable length	m	3
絶縁抵抗	Insulation resistance	Ohms	5000M
TEMPERATURE			
補償温度範囲	Compensated temperature range	°C	-10~+40
許容温度範囲	Safe temperature range	°C	-30~+80
出力の温度特性	Temperature effect on load	% of Reading/10°C	±0.015
零点の温度特性	Temperature effect on zero balance	% of R.O./10°C	±0.03*
ADVERSE LOAD RATING			
許容過負荷	Safe overload	% of Rated Capacity	150
限界過負荷	Ultimate overload	% of Rated Capacity	200

Note, ☆ 1 : Maximum deviation measured on increasing and decreasing load.
☆ 2 : Change in output for 30 minutes at rated load.

* ご要求により0.015%/5 °Cにすることができます

外形寸法図 DIMENSIONS

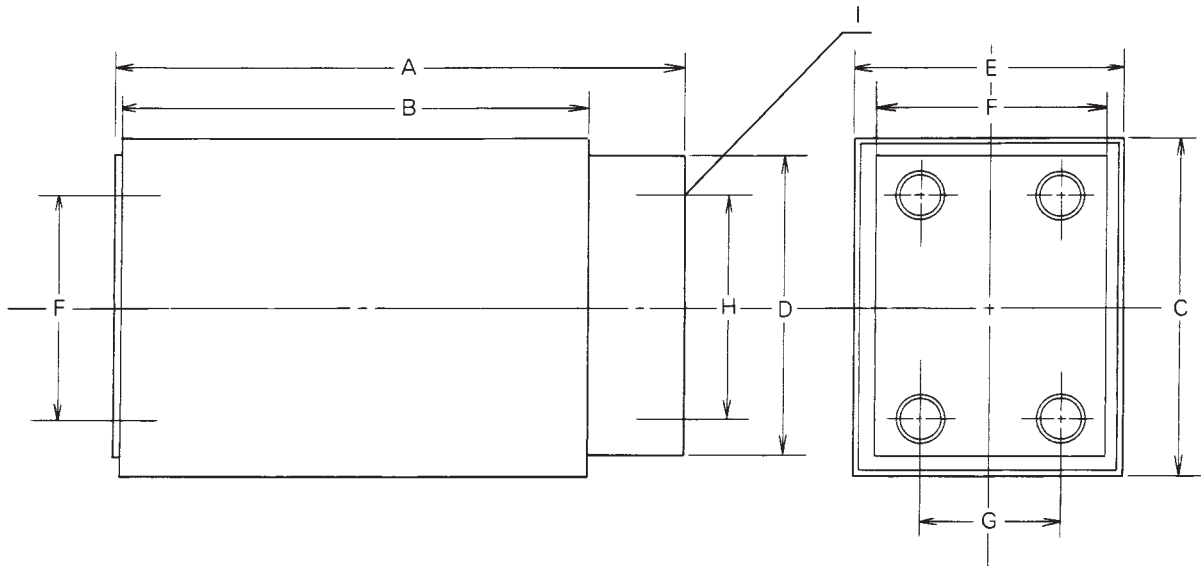

単位：mm

	kg	A	B	C	D	E	F	G	H	I
UHB61	50,100	156	130	83	75	55	44	24	50	M12
	250	156	130	83	75	70	60	24	50	M12
UHB62	250,500	146	120	105	95	70	60	36	70	M12
UHB63	1000,2000	176	150	135	125	86	76	46	95	M16

(ロードセルカバーはオプションになります)

負荷試験の誤差曲線の一部 TEST RESULT (sample UHB61-100-U)

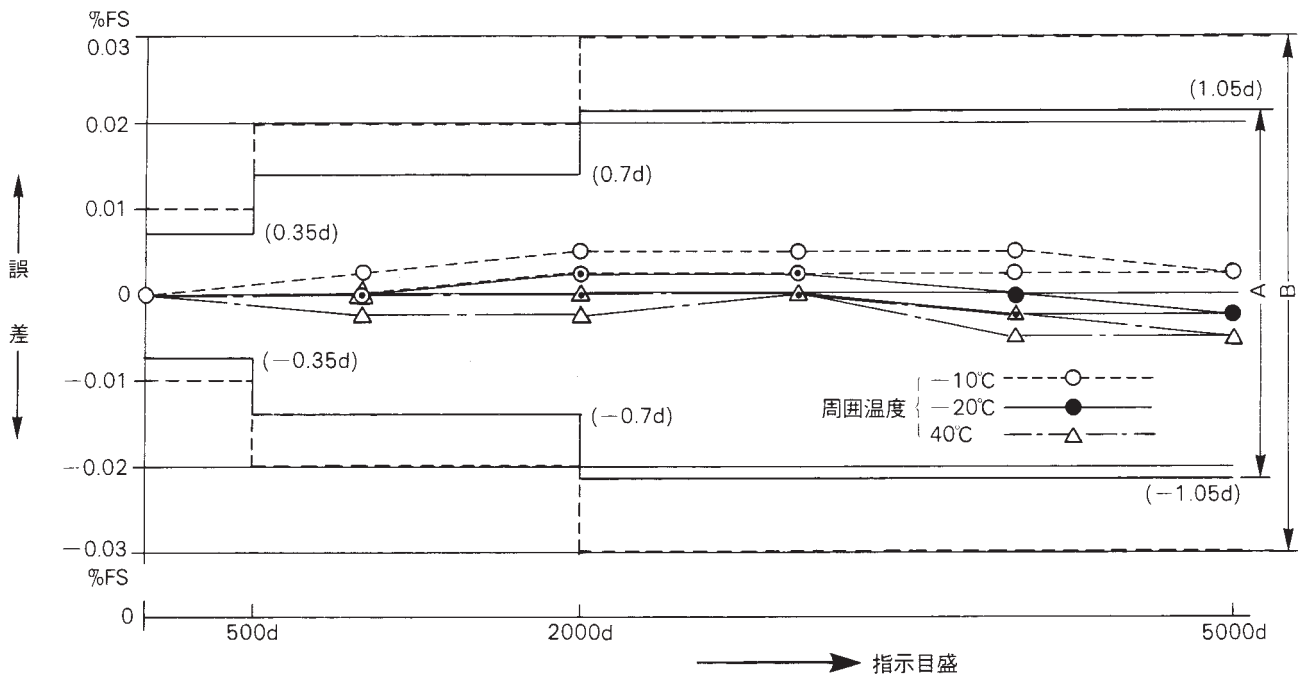

指示目盛

A : OILM国際勧告による $\frac{1}{5000}$ 級許容公差 (ロードセル)
 B : OILM国際勧告による $\frac{1}{5000}$ 級許容公差 (秤)

CD51/CS5

Capacity

model CD51 ; 500kg, 1, 2, 3, 5, 10t

model CS5 ; 5, 10, 20, 30, 50t

本質安全防爆 (i3AG4) 構造です。(CD51型)
 浮き上がり防止装置を標準装備し、直下型地震にも対応できる地震に強いロードセルユニットです。
 チェックロッド内蔵形のため、システム構成がシンプルで、設計計画が容易でトータルコストの節減ができます。(従来の70%のコスト当社従来比)

This has intrinsically safe dust-proof (i3AG4) construction. (Type CD51)
 This rugged load cell unit has standard equipment to prevent floating, and deals with earthquakes, even epicentral quakes.
 It has a simple construction, as it's a type with an internal check rod. The design layout is easy and is capable of curbing overall costs (by 70% compared with previous models made by Yamato).



SPECIFICATIONS			Accuracy Class	
			CD51 (V)	CS5 (H)
PERFORMANCE				
定格荷重出力	Rated Output (R.O.)	mv/v	2.0±0.005	2.0±0.005
直線性(ヒステリシスを含む)	Linearity including hysteresis	% of R.O.	±0.03	±0.1
繰返し性	Repeatability	% of R.O.	±0.015	±0.05
クリープ	Creep	% of R.O.	±0.03	±0.03
クリープ回復性	Recovery	% of R.O.	±0.03	±0.03
ELECTRICAL				
推奨印加電圧	Recommended excitation voltage	V ac or dc	10	10
最大印加電圧	Maximum excitation voltage	V ac or dc	15	15
零バランス	Zero balance	% of R.O.	±1	±1
入力端子間抵抗	Input terminal resistance	Ohms	700±20	700±10
出力端子間抵抗	Output terminal resistance	Ohms	700±5	700±2
ケーブル長さ	Cable length	m	5	5
絶縁抵抗	Insulation resistance	Ohms	5000M	5000M
TEMPERATURE				
補償温度範囲	Compensated temperature range	°C	-10~+60	-10~+60
許容温度範囲	Safe temperature range	°C	-30~+80	-30~+80
出力の温度特性	Temperature effect on load	% of Reading/10°C	±0.015	±0.05
零点の温度特性	Temperature effect on zero balance	% of R.O./5°C	±0.015	±0.025
ADVERSE LOAD RATING				
許容過負荷	Safe overload	% of Rated Capacity	150	150
限界過負荷	Ultimate overload	% of Rated Capacity	300 200 (10t)	300
許容横荷重		% of Rated Capacity	60	60
保護構造			IP67	IP65

外形寸法図 DIMENSIONS

■ CD51 型

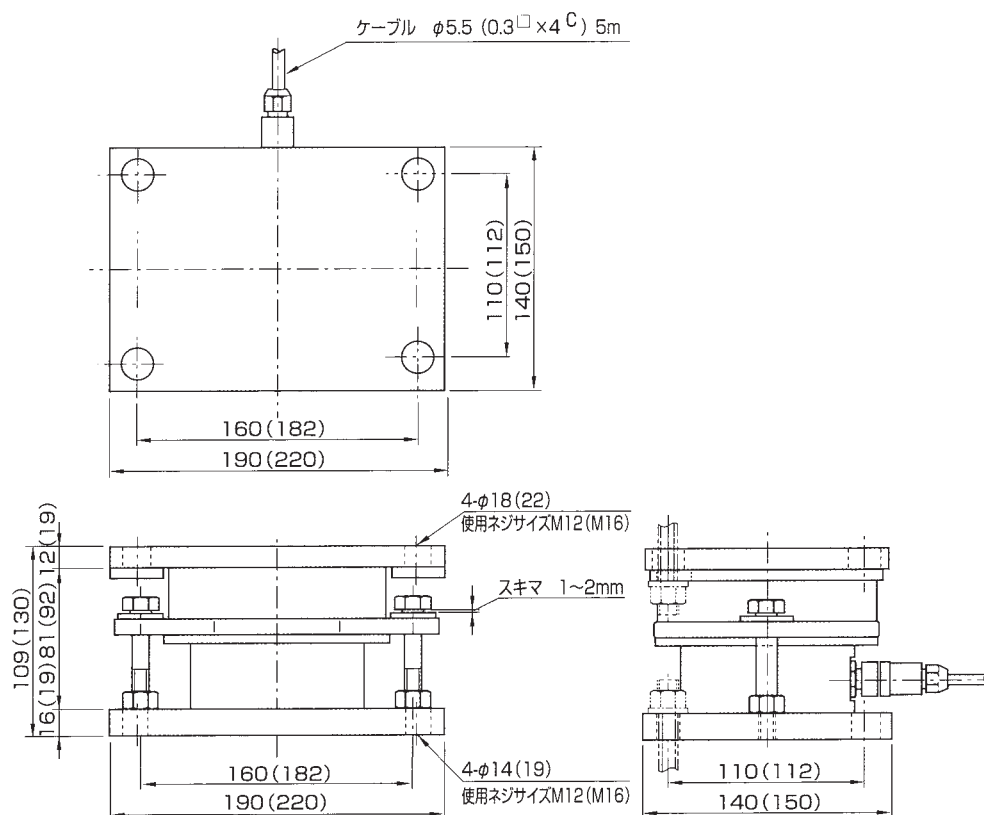

()内のみ10t用、()外寸法は500kg, 1t, 2t, 3t, 5t用
 ★CD51型ロードセルユニットの重量は、11.5kgです。(CD51-10Tは18kg)

Dimensions inside the brackets are only for 10t, dimensions outside the brackets are for 500kg, 1t, 2t, 3t, 5t.
 *The weight of the CD51 model load cell unit is 11.5 kg (18kg for the CD51-10T).

■ CS5 型

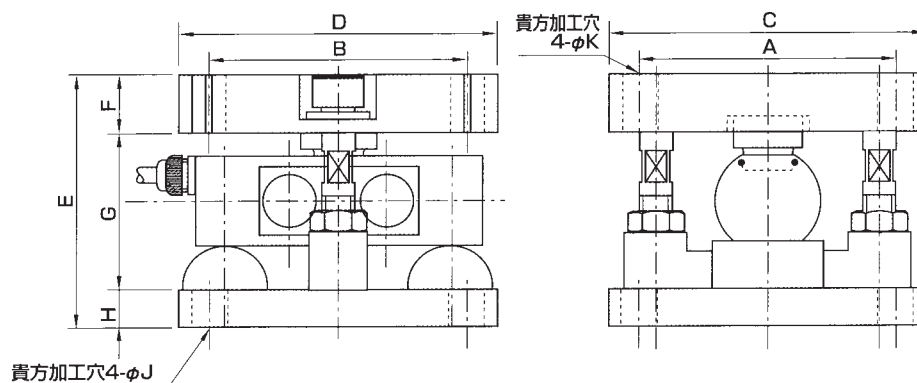

定格荷重	A	B	C	D	E	F	G	H	ϕJ	ϕK	WT (kg)
5t	120	120	160	160	110	27	68	15	18	18	9.5
10t	130	130	175	175	134	31	85	18	22	22	13.5
20t	160	160	210	210	162	38	100	24	22	22	23
30t	190	190	250	250	185	44	114	27	26	26	40
50t	240	240	300	300	230	53	146	31	26	26	68

注) 記載の内容は、予告なく変更することがありますのでご了承ください。

信頼・技術・創造

大和製衡株式会社



JQA-0698 JQA-EM5207

本社営業	〒673-8688 兵庫県明石市茶園場町5番22号	TEL.078-918-5555
東日本支店	〒105-0013 東京都港区浜松町1丁目22番5号	TEL.03-5776-3121
中日本支店	〒460-0008 名古屋市中区栄5丁目27番14号	TEL.052-238-5730
千葉営業所	〒264-0025 千葉市若葉区都賀4丁目8番18号	TEL.043-214-3920
九州営業所	〒812-0018 福岡市博多区住吉4丁目3番2号	TEL.092-471-1921
営業時間外緊急技術相談窓口		TEL.078-918-6168

URL : <http://www.yamato-scale.co.jp/>

YAMATO SCALE CO., LTD.

5-22 Saenba-cho, Akashi, Japan 673-8688

Telephone : +81(78)918-5566・5567・5568

Telefax : +81(78)918-5552